

(19) World Intellectual Property Organization  
International Bureau



(43) International Publication Date  
22 September 2011 (22.09.2011)

PCT

(10) International Publication Number  
**WO 2011/115873 A1**

(51) International Patent Classification:  
*F02B 33/22* (2006.01)

Beach Green, Shoreham-by-Sea, West Sussex BN43 5YE (GB).

(21) International Application Number:  
PCT/US2011/028285

(74) Agents: **FILDES, Christopher, J.** et al.; Fildes & Outland, P.C., 20916 Mack Avenue, Suite 2, Grosse Pointe Woods, MI 48236 (US).

(22) International Filing Date:  
14 March 2011 (14.03.2011)

(81) Designated States (unless otherwise indicated, for every kind of national protection available): AE, AG, AL, AM, AO, AT, AU, AZ, BA, BB, BG, BH, BR, BW, BY, BZ, CA, CH, CL, CN, CO, CR, CU, CZ, DE, DK, DM, DO, DZ, EC, EE, EG, ES, FI, GB, GD, GE, GH, GM, GT, HN, HR, HU, ID, IL, IN, IS, JP, KE, KG, KM, KN, KP, KR, KZ, LA, LC, LK, LR, LS, LT, LU, LY, MA, MD, ME, MG, MK, MN, MW, MX, MY, MZ, NA, NG, NI, NO, NZ, OM, PE, PG, PH, PL, PT, RO, RS, RU, SC, SD, SE, SG, SK, SL, SM, ST, SV, SY, TH, TJ, TM, TN, TR, TT, TZ, UA, UG, US, UZ, VC, VN, ZA, ZM, ZW.

(25) Filing Language: English

(26) Publication Language: English

(30) Priority Data:  
61/313,831 15 March 2010 (15.03.2010) US  
61/363,825 13 July 2010 (13.07.2010) US  
61/365,343 18 July 2010 (18.07.2010) US

(71) Applicant (for all designated States except US): **SCUDERI GROUP, LLC** [US/US]; 1111 Elm Street, Suite 33, West Springfield, MA 01089 (US).

(84) Designated States (unless otherwise indicated, for every kind of regional protection available): ARIPO (BW, GH, GM, KE, LR, LS, MW, MZ, NA, SD, SL, SZ, TZ, UG, ZM, ZW), Eurasian (AM, AZ, BY, KG, KZ, MD, RU, TJ, TM), European (AL, AT, BE, BG, CH, CY, CZ, DE, DK,

(72) Inventors: **MELDOLESI, Riccardo**; 55 New Road, Shoreham-by-Sea, West Sussex BN43 6RB (GB). **BADAIN, Nicholas**; 37 Rosslyn Road, Shoreham-by-Sea, West Sussex BN43 6WL (GB). **GILBERT, Ian**; 67

[Continued on next page]

(54) Title: SPLIT-CYCLE AIR-HYBRID ENGINE WITH AIR TANK VALVE

(57) Abstract: A split-cycle air-hybrid engine includes a rotatable crankshaft. A compression piston is slidably received within a compression cylinder. An expansion piston is slidably received within an expansion cylinder. A crossover passage interconnects the compression and expansion cylinders. The crossover passage includes a crossover compression (XovrC) valve and a crossover expansion (XovrE) valve. An air reservoir is operatively connected to the crossover passage. An air reservoir valve selectively controls air flow into and out of the air reservoir. In an Engine Firing (EF) mode, the air reservoir valve is kept closed. In an Air Expander (AE) and an Air Expander and Firing (AEF) mode, the air reservoir valve is kept open for a duration that is at least as long as a duration of the XovrE valve opening event. In an Air Compressor (AC) mode and a Firing and Charging (FC) mode, the air reservoir valve is selectively opened and closed.

FIG. 1

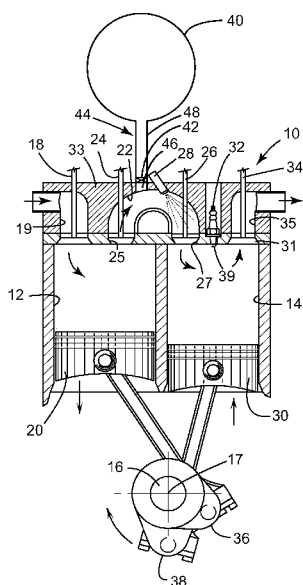

WO 2011/115873 A1

EE, ES, FI, FR, GB, GR, HR, HU, IE, IS, IT, LT, LU, **Published:**  
LV, MC, MK, MT, NL, NO, PL, PT, RO, RS, SE, SI, SK, — *with international search report (Art. 21(3))*  
SM, TR), OAPI (BF, BJ, CF, CG, CI, CM, GA, GN, GQ,  
GW, ML, MR, NE, SN, TD, TG).

**SPLIT-CYCLE AIR-HYBRID ENGINE WITH AIR TANK VALVE****TECHNICAL FIELD**

This invention relates to split-cycle engines and, more particularly, to such an engine incorporating an air-  
5 hybrid system.

**BACKGROUND OF THE INVENTION**

For purposes of clarity, the term "conventional  
10 engine" as used in the present application refers to an internal combustion engine wherein all four strokes of the well-known Otto cycle (i.e., the intake (or inlet), compression, expansion (or power) and exhaust strokes) are contained in each piston/cylinder combination of the engine.  
15 Each stroke requires one half revolution of the crankshaft (180 degrees crank angle (CA)), and two full revolutions of the crankshaft (720 degrees CA) are required to complete the entire Otto cycle in each cylinder of a conventional engine.

Also, for purposes of clarity, the following  
20 definition is offered for the term "split-cycle engine" as may be applied to engines disclosed in the prior art and as referred to in the present application.

A split-cycle engine as referred to herein comprises:

- 25 a crankshaft rotatable about a crankshaft axis;
- a compression piston slidably received within a compression cylinder and operatively connected to the crankshaft such that the compression piston reciprocates through an intake stroke and a compression stroke during a  
30 single rotation of the crankshaft;

an expansion (power) piston slidably received within an expansion cylinder and operatively connected to the crankshaft such that the expansion piston reciprocates through an expansion stroke and an exhaust stroke during a single rotation of the crankshaft; and

a crossover passage (port) interconnecting the compression and expansion cylinders, the crossover passage including at least a crossover expansion (XovrE) valve disposed therein, but more preferably including a crossover compression (XovrC) valve and a crossover expansion (XovrE) valve defining a pressure chamber therebetween.

United States Patent No. 6,543,225 granted April 8, 2003 to Scuderi and United States Patent No. 6,952,923 granted October 11, 2005 to Branyon et al., both of which are incorporated herein by reference, contain an extensive discussion of split-cycle and similar-type engines. In addition, these patents disclose details of prior versions of an engine of which the present disclosure details further developments.

Split-cycle air-hybrid engines combine a split-cycle engine with an air reservoir and various controls. This combination enables a split-cycle air-hybrid engine to store energy in the form of compressed air in the air reservoir. The compressed air in the air reservoir is later used in the expansion cylinder to power the crankshaft.

A split-cycle air-hybrid engine as referred to herein comprises:

a crankshaft rotatable about a crankshaft axis;  
a compression piston slidably received within a compression cylinder and operatively connected to the crankshaft such that the compression piston reciprocates through an intake stroke and a compression stroke during a single rotation of the crankshaft;

an expansion (power) piston slidably received within an expansion cylinder and operatively connected to the crankshaft such that the expansion piston reciprocates through an expansion stroke and an exhaust stroke during a single rotation of the crankshaft;

a crossover passage (port) interconnecting the compression and expansion cylinders, the crossover passage including at least a crossover expansion (XovrE) valve disposed therein, but more preferably including a crossover compression (XovrC) valve and a crossover expansion (XovrE) valve defining a pressure chamber therebetween; and

an air reservoir operatively connected to the crossover passage and selectively operable to store compressed air from the compression cylinder and to deliver compressed air to the expansion cylinder.

United States Patent No. 7,353,786 granted April 8, 2008 to Scuderi et al., which is incorporated herein by reference, contains an extensive discussion of split-cycle air-hybrid and similar-type engines. In addition, this patent discloses details of prior hybrid systems of which the present disclosure details further developments.

A split-cycle air-hybrid engine can be run in a normal operating or firing (NF) mode (also commonly called the Engine Firing (EF) mode) and four basic air-hybrid modes. In the EF mode, the engine functions as a non-air hybrid split-cycle engine, operating without the use of its air reservoir. In the EF mode, a tank valve operatively connecting the crossover passage to the air reservoir remains closed to isolate the air reservoir from the basic split-cycle engine.

The split-cycle air-hybrid engine operates with the use of its air reservoir in four hybrid modes. The four hybrid modes are:

- 1) Air Expander (AE) mode, which includes using compressed air energy from the air reservoir without combustion;
- 2) Air Compressor (AC) mode, which includes storing compressed air energy into the air reservoir without combustion;
- 3) Air Expander and Firing (AEF) mode, which includes using compressed air energy from the air reservoir with combustion; and
- 4) Firing and Charging (FC) mode, which includes storing compressed air energy into the air reservoir with combustion.

However, further optimization of these modes, EF, AE, AC, AEF and FC, is desirable to enhance efficiency and reduce emissions.

#### SUMMARY OF THE INVENTION

The present invention provides a split-cycle air-hybrid engine in which the use of the Engine Firing (EF), the Air Expander (AE), the Air Compressor (AC), the Air Expander and Firing (AEF), and the Firing and Charging (FC) modes are optimized for potentially any vehicle in any drive cycle for improved efficiency.

More particularly, an exemplary embodiment of a split-cycle air-hybrid engine in accordance with the present invention includes a crankshaft rotatable about a crankshaft axis. A compression piston is slidably received within a compression cylinder and operatively connected to the crankshaft such that the compression piston reciprocates through an intake stroke and a compression stroke during a single rotation of the crankshaft. An expansion piston is slidably received within an expansion cylinder and

operatively connected to the crankshaft such that the expansion piston reciprocates through an expansion stroke and an exhaust stroke during a single rotation of the crankshaft. A crossover passage interconnects the compression and expansion cylinders. The crossover passage includes a crossover compression (XovrC) valve and a crossover expansion (XovrE) valve defining a pressure chamber therebetween. An air reservoir is operatively connected to the crossover passage and selectively operable to store compressed air from the compression cylinder and to deliver compressed air to the expansion cylinder. An air reservoir valve selectively controls air flow into and out of the air reservoir. The engine is operable in one or more of an Engine Firing (EF) mode, an Air Expander (AE) mode, an Air Compressor (AC) mode, an Air Expander and Firing (AEF) mode, and a Firing and Charging (FC) mode. In the EF mode, the air reservoir valve is kept closed during the entire rotation of the crankshaft. In the AE and AEF modes, the air reservoir valve is kept open for a duration that is at least as long as a duration of the XovrE valve opening event. In the AC and FC modes, the air reservoir valve is selectively opened and closed during a single rotation of the crankshaft.

A method of operating a split-cycle air-hybrid engine is also disclosed. The split-cycle air-hybrid engine includes a crankshaft rotatable about a crankshaft axis. A compression piston is slidably received within a compression cylinder and operatively connected to the crankshaft such that the compression piston reciprocates through an intake stroke and a compression stroke during a single rotation of the crankshaft. An expansion piston is slidably received within an expansion cylinder and operatively connected to the crankshaft such that the expansion piston reciprocates

through an expansion stroke and an exhaust stroke during a single rotation of the crankshaft. A crossover passage interconnects the compression and expansion cylinders. The crossover passage includes a crossover compression (XovrC) valve and a crossover expansion (XovrE) valve defining a pressure chamber therebetween. An air reservoir is operatively connected to the crossover passage and selectively operable to store compressed air from the compression cylinder and to deliver compressed air to the expansion cylinder. An air reservoir valve selectively controls air flow into and out of the air reservoir. The engine is operable in one or more of an Engine Firing (EF) mode, an Air Expander (AE) mode, an Air Compressor (AC) mode, an Air Expander and Firing (AEF) mode, and a Firing and Charging (FC) mode. The method in accordance with the present invention includes the following steps: in the EF mode, keeping the air reservoir valve closed during the entire rotation of the crankshaft to isolate the air reservoir; in the AE and AEF modes, keeping the air reservoir valve open for a duration that is at least as long as a duration of the XovrE valve opening event to allow for use of stored compressed air; and in the AC and FC modes, selectively opening and closing the air reservoir valve during a single rotation of the crankshaft to allow for flow of compressed air into the air reservoir for storage of compressed air.

These and other features and advantages of the invention will be more fully understood from the following detailed description of the invention taken together with the accompanying drawings.



**BRIEF DESCRIPTION OF THE DRAWINGS**

In the drawings:

FIG. 1 is a lateral sectional view of an exemplary  
5 split-cycle air-hybrid engine in accordance with the present  
invention;

FIG. 2 is a lateral view of an exemplary air tank  
valve of the split-cycle air-hybrid engine; and

FIG. 3 is a perspective view of the air tank valve  
10 of FIG. 2.

**DETAILED DESCRIPTION OF THE INVENTION**

The following glossary of acronyms and definitions  
15 of terms used herein is provided for reference.

In General

Unless otherwise specified, all valve opening and  
closing timings are measured in crank angle degrees after  
top dead center of the expansion piston (ATDCe).

20 Unless otherwise specified, all valve durations  
are in crank angle degrees (CA).

Air tank (or air storage tank): Storage tank for compressed  
air.

ATDCe: After top dead center of the expansion piston.

25 Bar: Unit of pressure,  $1 \text{ bar} = 10^5 \text{ N/m}^2$

Compressor: The compression cylinder and its associated  
compression piston of a split-cycle engine.

Expander: The expansion cylinder and its associated  
expansion piston of a split-cycle engine.

30 Flow control valve(s): Device(s) inserted into the pipework  
which can control the flow in that pipework.

Reed valve: A pressure activated valve where the control  
element is a flexible plate which seals against a fixed

housing and blocks flow in a forward direction. When pressure builds up on the reverse side of the plate, the plate deflects and opens, allowing flow in the reverse direction.

5 Tank valve: Valve connecting the Xovr passage with the compressed air storage tank.

VVA: Variable valve actuation. A mechanism or method operable to alter the shape or timing of a valve's lift profile.

10 Xovr (or Xover) valve, passage or port: The crossover valves, passages, and/or ports which connect the compression and expansion cylinders through which gas flows from compression to expansion cylinder.

15 XovrC (or XoverC) valves: Valves at the compressor end of the Xovr passage.

XovrE (or XoverE) valves: Valves at the expander end of the crossover (Xovr) passage.

Referring to FIG. 1, an exemplary split-cycle air-hybrid engine is shown generally by numeral 10. The split-cycle air-hybrid engine 10 replaces two adjacent cylinders of a conventional engine with a combination of one compression cylinder 12 and one expansion cylinder 14. A cylinder head 33 is typically disposed over an open end of the expansion and compression cylinders 12, 14 to cover and seal the cylinders.

20  
25

The four strokes of the Otto cycle are "split" over the two cylinders 12 and 14 such that the compression cylinder 12, together with its associated compression piston 20, perform the intake and compression strokes, and the expansion cylinder 14, together with its associated expansion piston 30, perform the expansion and exhaust strokes. The Otto cycle is therefore completed in these two

30

cylinders 12, 14 once per crankshaft 16 revolution (360 degrees CA) about crankshaft axis 17.

During the intake stroke, intake air is drawn into the compression cylinder 12 through an intake port 19 disposed in the cylinder head 33. An inwardly opening (opening inwardly into the cylinder and toward the piston) poppet intake valve 18 controls fluid communication between the intake port 19 and the compression cylinder 12.

During the compression stroke, the compression piston 20 pressurizes the air charge and drives the air charge into the crossover passage (or port) 22, which is typically disposed in the cylinder head 33. This means that the compression cylinder 12 and compression piston 20 are a source of high-pressure gas to the crossover passage 22, which acts as the intake passage for the expansion cylinder 14. In some embodiments, two or more crossover passages 22 interconnect the compression cylinder 12 and the expansion cylinder 14.

The geometric (or volumetric) compression ratio of the compression cylinder 12 of split-cycle engine 10 (and for split-cycle engines in general) is herein commonly referred to as the "compression ratio" of the split-cycle engine. The geometric (or volumetric) compression ratio of the expansion cylinder 14 of split-cycle engine 10 (and for split-cycle engines in general) is herein commonly referred to as the "expansion ratio" of the split-cycle engine. The geometric compression ratio of a cylinder is well known in the art as the ratio of the enclosed (or trapped) volume in the cylinder (including all recesses) when a piston reciprocating therein is at its bottom dead center (BDC) position to the enclosed volume (i.e., clearance volume) in the cylinder when said piston is at its top dead center (TDC) position. Specifically for split-cycle engines as

defined herein, the compression ratio of a compression cylinder is determined when the XovrC valve is closed. Also specifically for split-cycle engines as defined herein, the expansion ratio of an expansion cylinder is determined when  
5 the XovrE valve is closed.

Due to very high compression ratios (e.g., 20 to 1, 30 to 1, 40 to 1, or greater) within the compression cylinder 12, an outwardly opening (opening outwardly away from the cylinder) poppet crossover compression (XovrC)  
10 valve 24 at the crossover passage inlet 25 is used to control flow from the compression cylinder 12 into the crossover passage 22. Due to very high expansion ratios (e.g., 20 to 1, 30 to 1, 40 to 1, or greater) within the expansion cylinder 14, an outwardly opening poppet crossover  
15 expansion (XovrE) valve 26 at the outlet 27 of the crossover passage 22 controls flow from the crossover passage 22 into the expansion cylinder 14. The actuation rates and phasing of the XovrC and XovrE valves 24, 26 are timed to maintain pressure in the crossover passage 22 at a high minimum  
20 pressure (typically 20 bar or higher at full load) during all four strokes of the Otto cycle.

At least one fuel injector 28 injects fuel into the pressurized air at the exit end of the crossover passage 22 in correspondence with the XovrE valve 26 opening, which  
25 occurs shortly before expansion piston 30 reaches its top dead center position. The air/fuel charge enters the expansion cylinder 14 when expansion piston 30 is close to its top dead center position. As piston 30 begins its descent from its top dead center position, and while the XovrE valve 26 is still open, spark plug 32, which includes  
30 a spark plug tip 39 that protrudes into cylinder 14, is fired to initiate combustion in the region around the spark plug tip 39. Combustion can be initiated while the

expansion piston is between 1 and 30 degrees CA past its top dead center (TDC) position. More preferably, combustion can be initiated while the expansion piston is between 5 and 25 degrees CA past its top dead center (TDC) position. Most preferably, combustion can be initiated while the expansion piston is between 10 and 20 degrees CA past its top dead center (TDC) position. Additionally, combustion may be initiated through other ignition devices and/or methods, such as with glow plugs, microwave ignition devices or through compression ignition methods.

During the exhaust stroke, exhaust gases are pumped out of the expansion cylinder 14 through exhaust port 35 disposed in cylinder head 33. An inwardly opening poppet exhaust valve 34, disposed in the inlet 31 of the exhaust port 35, controls fluid communication between the expansion cylinder 14 and the exhaust port 35. The exhaust valve 34 and the exhaust port 35 are separate from the crossover passage 22. That is, exhaust valve 34 and the exhaust port 35 do not make contact with, or are not disposed in, the crossover passage 22.

With the split-cycle engine concept, the geometric engine parameters (i.e., bore, stroke, connecting rod length, volumetric compression ratio, etc.) of the compression 12 and expansion 14 cylinders are generally independent from one another. For example, the crank throws 36, 38 for the compression cylinder 12 and expansion cylinder 14, respectively, may have different radii and may be phased apart from one another such that top dead center (TDC) of the expansion piston 30 occurs prior to TDC of the compression piston 20. This independence enables the split-cycle engine 10 to potentially achieve higher efficiency levels and greater torques than typical four-stroke engines.

The geometric independence of engine parameters in the split-cycle engine 10 is also one of the main reasons why pressure can be maintained in the crossover passage 22 as discussed earlier. Specifically, the expansion piston 30 reaches its top dead center position prior to the compression piston reaching its top dead center position by a discreet phase angle (typically between 10 and 30 crank angle degrees). This phase angle, together with proper timing of the XovrC valve 24 and the XovrE valve 26, enables the split-cycle engine 10 to maintain pressure in the crossover passage 22 at a high minimum pressure (typically 20 bar absolute or higher during full load operation) during all four strokes of its pressure/volume cycle. That is, the split-cycle engine 10 is operable to time the XovrC valve 24 and the XovrE valve 26 such that the XovrC and XovrE valves are both open for a substantial period of time (or period of crankshaft rotation) during which the expansion piston 30 descends from its TDC position towards its BDC position and the compression piston 20 simultaneously ascends from its BDC position towards its TDC position. During the period of time (or crankshaft rotation) that the crossover valves 24, 26 are both open, a substantially equal mass of air is transferred (1) from the compression cylinder 12 into the crossover passage 22 and (2) from the crossover passage 22 to the expansion cylinder 14. Accordingly, during this period, the pressure in the crossover passage is prevented from dropping below a predetermined minimum pressure (typically 20, 30, or 40 bar absolute during full load operation). Moreover, during a substantial portion of the engine cycle (typically 80% of the entire engine cycle or greater), the XovrC valve 24 and XovrE valve 26 are both closed to maintain the mass of trapped gas in the crossover passage 22 at a substantially constant level. As a result,

the pressure in the crossover passage 22 is maintained at a predetermined minimum pressure during all four strokes of the engine's pressure/volume cycle.

For purposes herein, the method of having the XovrC 24 and XovrE 26 valves open while the expansion piston 30 is descending from TDC and the compression piston 20 is ascending toward TDC in order to simultaneously transfer a substantially equal mass of gas into and out of the crossover passage 22 is referred to herein as the Push-Pull method of gas transfer. It is the Push-Pull method that enables the pressure in the crossover passage 22 of the split-cycle engine 10 to be maintained at typically 20 bar or higher during all four strokes of the engine's cycle when the engine is operating at full load.

As discussed earlier, the exhaust valve 34 is disposed in the exhaust port 35 of the cylinder head 33 separate from the crossover passage 22. The structural arrangement of the exhaust valve 34 not being disposed in the crossover passage 22, and therefore the exhaust port 35 not sharing any common portion with the crossover passage 22, is preferred in order to maintain the trapped mass of gas in the crossover passage 22 during the exhaust stroke. Accordingly, large cyclic drops in pressure are prevented which may force the pressure in the crossover passage below the predetermined minimum pressure.

XovrE valve 26 opens shortly before the expansion piston 30 reaches its top dead center position. At this time, the pressure ratio of the pressure in crossover passage 22 to the pressure in expansion cylinder 14 is high, due to the fact that the minimum pressure in the crossover passage is typically 20 bar absolute or higher and the pressure in the expansion cylinder during the exhaust stroke is typically about one to two bar absolute. In other words,

when XovrE valve 26 opens, the pressure in crossover passage 22 is substantially higher than the pressure in expansion cylinder 14 (typically in the order of 20 to 1 or greater). This high pressure ratio causes initial flow of the air and/or fuel charge to flow into expansion cylinder 14 at high speeds. These high flow speeds can reach the speed of sound, which is referred to as sonic flow. This sonic flow is particularly advantageous to split-cycle engine 10 because it causes a rapid combustion event, which enables the split-cycle engine 10 to maintain high combustion pressures even though ignition is initiated while the expansion piston 30 is descending from its top dead center position.

The split-cycle air-hybrid engine 10 also includes an air reservoir (tank) 40, which is operatively connected to the crossover passage 22 by an air reservoir (tank) valve 42. Embodiments with two or more crossover passages 22 may include a tank valve 42 for each crossover passage 22, which connect to a common air reservoir 40, or alternatively each crossover passage 22 may operatively connect to separate air reservoirs 40.

The tank valve 42 is typically disposed in an air reservoir (tank) port 44, which extends from crossover passage 22 to the air tank 40. The air tank port 44 is divided into a first air reservoir (tank) port section 46 and a second air reservoir (tank) port section 48. The first air tank port section 46 connects the air tank valve 42 to the crossover passage 22, and the second air tank port section 48 connects the air tank valve 42 to the air tank 40. The volume of the first air tank port section 46 includes the volume of all additional ports and recesses which connect the tank valve 42 to the crossover passage 22 when the tank valve 42 is closed.



The tank valve 42 may be any suitable valve device or system. For example, the tank valve 42 may be an active valve which is activated by various valve actuation devices (e.g., pneumatic, hydraulic, cam, electric or the like).  
5 Additionally, the tank valve 42 may comprise a tank valve system with two or more valves actuated with two or more actuation devices.

Air tank 40 is utilized to store energy in the form of compressed air and to later use that compressed air  
10 to power the crankshaft 16, as described in the aforementioned United States Patent No. 7,353,786 to Scuderi et al. This mechanical means for storing potential energy provides numerous potential advantages over the current state of the art. For instance, the split-cycle engine  
15 can potentially provide many advantages in fuel efficiency gains and NOx emissions reduction at relatively low manufacturing and waste disposal costs in relation to other technologies on the market, such as diesel engines and electric-hybrid systems.

20 By selectively controlling the opening and/or closing of the air tank valve 42 and thereby controlling communication of the air tank 40 with the crossover passage 22, the split-cycle air-hybrid engine 10 is operable in an Engine Firing (EF) mode, an Air Expander (AE) mode, an Air  
25 Compressor (AC) mode, an Air Expander and Firing (AEF) mode, and a Firing and Charging (FC) mode. The EF mode is a non-hybrid mode in which the engine operates as described above without the use of the air tank 40. The AC and FC modes are energy storage modes. The AC mode is an air-hybrid  
30 operating mode in which compressed air is stored in the air tank 40 without combustion occurring in the expansion cylinder 14 (i.e., no fuel expenditure), such as by utilizing the kinetic energy of a vehicle including the

engine 10 during braking. The FC mode is an air-hybrid operating mode in which excess compressed air not needed for combustion is stored in the air tank 40, such as at less than full engine load (e.g., engine idle, vehicle cruising at constant speed). The storage of compressed air in the FC mode has an energy cost (penalty); therefore, it is desirable to have a net gain when the compressed air is used at a later time. The AE and AEF modes are stored energy usage modes. The AE mode is an air-hybrid operating mode in which compressed air stored in the air tank 40 is used to drive the expansion piston 30 without combustion occurring in the expansion cylinder 14 (i.e., no fuel expenditure). The AEF mode is an air-hybrid operating mode in which compressed air stored in the air tank 40 is utilized in the expansion cylinder 14 for combustion.

The air tank valve 42 may be a fully controllable variably actuated valve that can be kept closed, held open, or selectively opened and closed at any desired timing. In the EF mode, the air reservoir valve 42 is kept closed during the entire rotation of the crankshaft 16 to isolate the air reservoir 40 from the rest of the engine. In the AE and AEF modes, the air reservoir valve 42 is kept open for a duration (in CA degrees) that is at least as long as a duration of the XovrE valve 26 opening event, to allow for use in the expansion cylinder 14 of previously stored compressed air. In a specific embodiment, in the AE and AEF modes, the air reservoir valve 42 may be kept open during the entire rotation of the crankshaft 16. In the AC and FC modes, the air reservoir valve 42 is selectively opened and closed during a single rotation of the crankshaft 16 to allow for flow of compressed air into the air reservoir 40 in order to store the compressed air for later use.

In the EF mode, the compression piston 20 draws in and compresses inlet air for use in the expansion cylinder 14. The compressed air from the compression cylinder 12 is admitted to the expansion cylinder 14 with fuel, at the beginning of an expansion stroke, which is ignited, burned and expanded on the same expansion stroke of the expansion piston 30, transmitting power to the crankshaft 16, and the combustion products are discharged on the exhaust stroke. Since compressed air is neither stored in nor released from the air tank 40 in the EF mode, the air tank valve 42 is closed.

In the AE mode, compressed air stored in the air tank 40 is admitted to the expansion cylinder 14, at the beginning of an expansion stroke. Since in this mode the air tank valve 42 is kept open at least as long as the XovrE valve 26, air flow into the expansion cylinder 14 is controlled by the XovrE valve. The air is expanded on the same expansion stroke of the expansion piston 30, transmitting power to the crankshaft 16, and the (expanded) air is discharged on the exhaust stroke.

In the AEF mode, compressed air stored in the air tank 40 is admitted to the expansion cylinder 14 with fuel, at the beginning of an expansion stroke. Since in this mode the air tank valve 42 is kept open at least as long as the XovrE valve 26, flow of the air/fuel mixture into the expansion cylinder 14 is controlled by the XovrE valve 26. The air/fuel mixture is ignited, burned and expanded on the same expansion stroke of the expansion piston 30, transmitting power to the crankshaft 16, and the combustion products are discharged on the exhaust stroke.

In the AC mode, the compression piston 20 draws in and compresses inlet air. The compressed air is then stored

in the air tank 40 by selectively opening and then closing the air tank valve 42.

In the FC mode, the compression piston 20 draws in and compresses inlet air for use in the expansion cylinder 14 during a single rotation of the crankshaft 16. Some of the compressed air from the compression cylinder 12 is admitted to the expansion cylinder 14 with fuel, at the beginning of an expansion stroke, which is ignited, burned and expanded on the same expansion stroke of the expansion piston, transmitting power to the crankshaft, and the combustion products are discharged on the exhaust stroke. The air tank 40 is also charged with compressed air during the same single rotation of the crankshaft 16 by selectively opening and then closing the air tank valve 42.

In an exemplary embodiment shown in FIGS. 2 and 3, the air tank valve 42 is an outwardly opening poppet valve disposed in the air reservoir port 44 and connected to the crossover passage 22. The air tank port 44 has an angular bend (i.e., elbow) allowing the stem 43 of the valve 42 to extend vertically from the valve head. The angular bend is shown as a generally right-angle bend, but may be an S-curve or other similarly shaped elbow. A pneumatic, hydraulic, electric or mechanical valve actuation device 45 or the like may be disposed at the distal end of the stem 43. While the air tank valve 42 is exemplified as an outwardly opening poppet valve, one of ordinary skill in the art would realize that the air tank valve may be one or more of, or a combination thereof, the following valve types: an inwardly opening poppet valve, a rotary valve, a sleeve valve, a pintle valve, or the like, and may include a pressure activated check valve (such as a reed valve) in the combination.

Although the invention has been described by reference to specific embodiments, it should be understood that numerous changes may be made within the spirit and scope of the inventive concepts described. Accordingly, it is intended that the invention not be limited to the described 5 embodiments, but that it have the full scope defined by the language of the following claims.

**CLAIMS**

What is claimed is:

1. A split-cycle air-hybrid engine comprising:
  - 5 a crankshaft rotatable about a crankshaft axis;
  - a compression piston slidably received within a compression cylinder and operatively connected to the crankshaft such that the compression piston reciprocates through an intake stroke and a compression stroke during a  
10 single rotation of the crankshaft;
  - an expansion piston slidably received within an expansion cylinder and operatively connected to the crankshaft such that the expansion piston reciprocates through an expansion stroke and an exhaust stroke during a  
15 single rotation of the crankshaft;
  - a crossover passage interconnecting the compression and expansion cylinders, the crossover passage including a crossover compression (XovrC) valve and a crossover expansion (XovrE) valve defining a pressure  
20 chamber therebetween;
  - an air reservoir operatively connected to the crossover passage and selectively operable to store compressed air from the compression cylinder and to deliver compressed air to the expansion cylinder; and  
25 an air reservoir valve selectively controlling air flow into and out of the air reservoir;
  - the engine being operable in one or more of an Engine Firing (EF) mode, an Air Expander (AE) mode, an Air Compressor (AC) mode, an Air Expander and Firing (AEF) mode,  
30 and a Firing and Charging (FC) mode, wherein:
    - in the EF mode, the air reservoir valve is kept closed during the entire rotation of the crankshaft;

in the AE and AEF modes, the air reservoir valve is kept open for a duration that is at least as long as a duration of the XovrE valve opening event; and

in the AC and FC modes, the air reservoir valve is  
5 selectively opened and closed during a single rotation of the crankshaft.

2. The split-cycle air-hybrid engine of claim 1, wherein the air reservoir valve is an outwardly opening poppet valve.

10 3. The split-cycle air-hybrid engine of claim 1, wherein the air reservoir valve is a fully controllable variably actuated valve.

4. The split-cycle air-hybrid engine of claim 1, wherein the air reservoir valve is kept open for an entire  
15 rotation of the crankshaft.

5. The split-cycle air-hybrid engine of claim 1, wherein, in the AE and AEF modes, air flow into the expansion cylinder is controlled by the XovrE valve.

6. The split-cycle air-hybrid engine of claim 1,  
20 wherein, in the EF mode, the compression piston draws in and compresses inlet air for use in the expansion cylinder, and compressed air is admitted to the expansion cylinder with fuel, at the beginning of an expansion stroke, which is ignited, burned and expanded on the same expansion stroke of  
25 the expansion piston, transmitting power to the crankshaft, and the combustion products are discharged on the exhaust stroke.

7. The split-cycle air-hybrid engine of claim 1, wherein, in the AE mode, compressed air from the air  
30 reservoir is admitted to the expansion cylinder, at the beginning of an expansion stroke, the air is expanded on the same expansion stroke of the expansion piston, transmitting

power to the crankshaft, and the air is discharged on the exhaust stroke.

8. The split-cycle air-hybrid engine of claim 1, wherein, in the AEF mode, compressed air from the air reservoir is admitted to the expansion cylinder with fuel, at the beginning of an expansion stroke, which is ignited, burned and expanded on the same expansion stroke of the expansion piston, transmitting power to the crankshaft, and the combustion products are discharged on the exhaust stroke.

9. The split-cycle air-hybrid engine of claim 1, wherein, in the AC mode, the compression piston draws in and compresses inlet air, which is stored in the air reservoir.

10. The split-cycle air-hybrid engine of claim 1, wherein, in the FC mode, the compression piston draws in and compresses inlet air for use in the expansion cylinder during a single rotation of the crankshaft, and compressed air is admitted to the expansion cylinder with fuel, at the beginning of an expansion stroke, which is ignited, burned and expanded on the same expansion stroke of the expansion piston, transmitting power to the crankshaft, and the combustion products are discharged on the exhaust stroke, and the air reservoir is charged with compressed air during the same single rotation of the crankshaft.

11. A method of operating a split-cycle air-hybrid engine including:

a crankshaft rotatable about a crankshaft axis;

a compression piston slidably received within a compression cylinder and operatively connected to the crankshaft such that the compression piston reciprocates through an intake stroke and a compression stroke during a single rotation of the crankshaft;



an expansion piston slidably received within an expansion cylinder and operatively connected to the crankshaft such that the expansion piston reciprocates through an expansion stroke and an exhaust stroke during a single rotation of the crankshaft;

5 a crossover passage interconnecting the compression and expansion cylinders, the crossover passage including a crossover compression (XovrC) valve and a crossover expansion (XovrE) valve defining a pressure chamber therebetween;

10 an air reservoir operatively connected to the crossover passage and selectively operable to store compressed air from the compression cylinder and to deliver compressed air to the expansion cylinder; and

15 an air reservoir valve selectively controlling air flow into and out of the air reservoir;

the engine being operable in one or more of an Engine Firing (EF) mode, an Air Expander (AE) mode, an Air Compressor (AC) mode, an Air Expander and Firing (AEF) mode, and a Firing and Charging (FC) mode;

the method including the steps of:

in the EF mode, keeping the air reservoir valve closed during the entire rotation of the crankshaft to isolate the air reservoir;

25 in the AE and AEF modes, keeping the air reservoir valve open for a duration that is at least as long as a duration of the XovrE valve opening event; and

in the AC and FC modes, selectively opening and closing the air reservoir valve during a single rotation of the crankshaft to allow for flow of compressed air into the air reservoir for storage of compressed air.

30 12. The method of claim 11, further including the step of:

in the AE and AEF modes, keeping the air reservoir valve open for an entire rotation of the crankshaft.

13. The method of claim 11, further including the steps of:

5           selecting one of the AE mode and the AEF mode; and  
          controlling air flow into the expansion cylinder by opening and closing the XovrE valve.

14. The method of claim 11, further including the steps of:

10           selecting the EF mode;  
          drawing in and compressing inlet air with the compression piston; and

          admitting compressed air from the compression cylinder into the expansion cylinder with fuel, at the  
15 beginning of an expansion stroke, the fuel being ignited, burned and expanded on the same expansion stroke of the expansion piston, transmitting power to the crankshaft, and discharging the combustion products on the exhaust stroke.

15. The method of claim 11, further including the steps of:

20           selecting the AE mode; and  
          admitting compressed air from the air reservoir into the expansion cylinder, at the beginning of an expansion stroke, expanding the air on the same expansion  
25 stroke of the expansion piston, transmitting power to the crankshaft, and discharging the air on the exhaust stroke.

16. The method of claim 11, further including the steps of:

30           selecting the AEF mode; and  
          admitting compressed air from the air reservoir into the expansion cylinder with fuel, at the beginning of an expansion stroke, which is ignited, burned and expanded on the same expansion stroke of the expansion piston,

transmitting power to the crankshaft, and discharging the combustion products on the exhaust stroke.

17. The method of claim 11, further including the steps of:

5           selecting the AC mode;

          drawing in and compressing inlet air with the compression piston; and

          storing the compressed air in the air reservoir.

18. The method of claim 11, further including the  
10 steps of:

          selecting the FC mode;

          drawing in and compressing inlet air with the compression piston during a single rotation of the crankshaft;

15           admitting compressed air into the expansion cylinder with fuel, at the beginning of an expansion stroke, the fuel being ignited, burned and expanded on the same expansion stroke of the expansion piston, transmitting power to the crankshaft, and discharging the combustion products  
20 on the exhaust stroke; and

          charging the air reservoir with compressed air during the said single rotation of the crankshaft.

FIG. 1

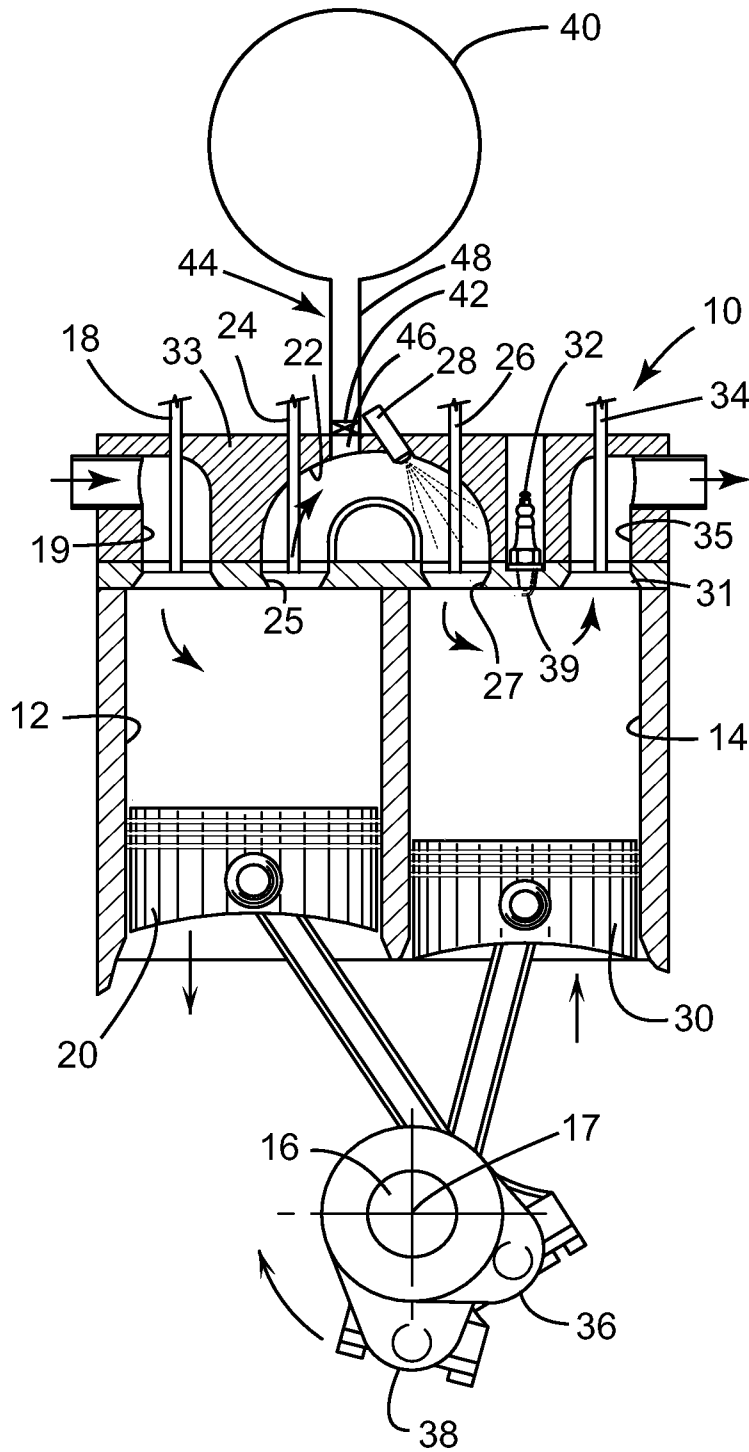

FIG. 2

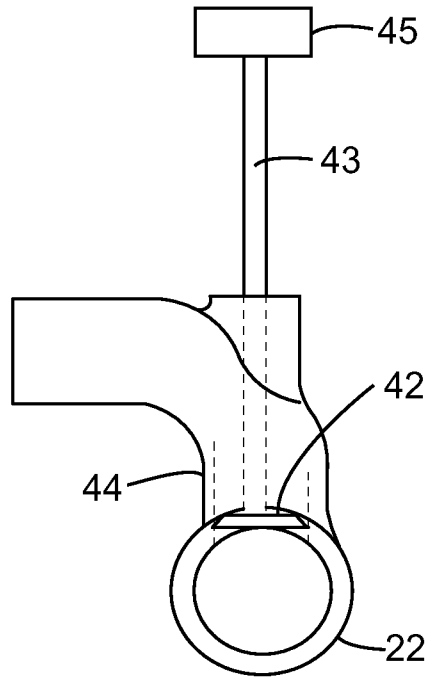
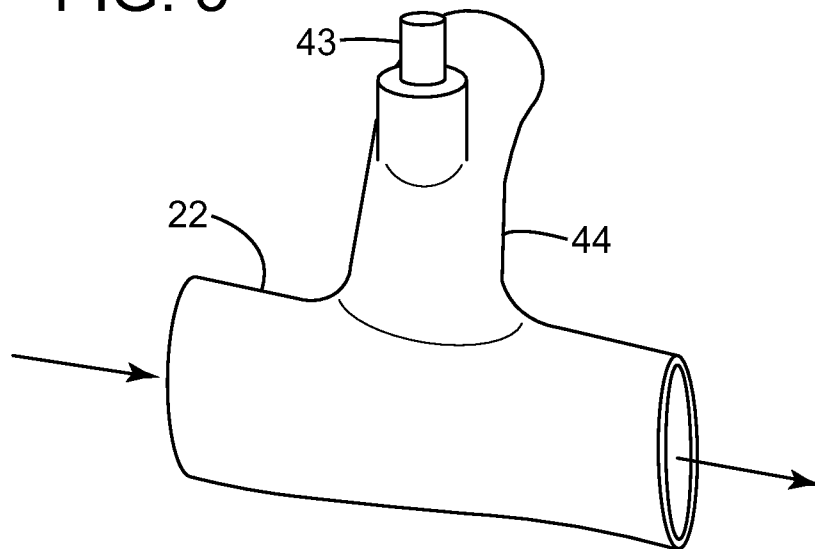

FIG. 3



INTERNATIONAL SEARCH REPORT

International application No.  
PCT/US2011/028285

A. CLASSIFICATION OF SUBJECT MATTER  
IPC(8) - F02B 33/22 (2011.01)  
USPC - 123/70R  
According to International Patent Classification (IPC) or to both national classification and IPC

B. FIELDS SEARCHED  
Minimum documentation searched (classification system followed by classification symbols)  
IPC(8) - F02B 3/00, 11/00, 19/06, 33/00, 33/02, 33/06, 33/22, 41/02, 41/04, 41/06 (2011.01)  
USPC - 60/620, 712; 123/26, 27R, 52.3, 52.5, 53.1, 53.5, 58.8, 68, 70R, 70V, 253, 258, 286, 292; 180/165, 302

Documentation searched other than minimum documentation to the extent that such documents are included in the fields searched

Electronic data base consulted during the international search (name of data base and, where practicable, search terms used)  
PatBase

C. DOCUMENTS CONSIDERED TO BE RELEVANT

Category*	Citation of document, with indication, where appropriate, of the relevant passages	Relevant to claim No.
X - Y	US 2007/0157894 A1 (SCUDERI et al) 12 July 2007 (12.07.2007) entire document	1, 3-18 ----- 2
Y	US 2010/0051003 A1 (NEGRE et al) 04 March 2010 (04.03.2010) entire document	2

Further documents are listed in the continuation of Box C.

\* Special categories of cited documents:  
 "A" document defining the general state of the art which is not considered to be of particular relevance  
 "E" earlier application or patent but published on or after the international filing date  
 "L" document which may throw doubts on priority claim(s) or which is cited to establish the publication date of another citation or other special reason (as specified)  
 "O" document referring to an oral disclosure, use, exhibition or other means  
 "P" document published prior to the international filing date but later than the priority date claimed  
 "T" later document published after the international filing date or priority date and not in conflict with the application but cited to understand the principle or theory underlying the invention  
 "X" document of particular relevance; the claimed invention cannot be considered novel or cannot be considered to involve an inventive step when the document is taken alone  
 "Y" document of particular relevance; the claimed invention cannot be considered to involve an inventive step when the document is combined with one or more other such documents, such combination being obvious to a person skilled in the art  
 "&" document member of the same patent family

Date of the actual completion of the international search 05 May 2011	Date of mailing of the international search report <b>20 MAY 2011</b>
--	--

Name and mailing address of the ISA/US Mail Stop PCT, Attn: ISA/US, Commissioner for Patents P.O. Box 1450, Alexandria, Virginia 22313-1450 Facsimile No. 571-273-3201	Authorized officer: Blaine R. Copenheaver PCT Helpdesk: 571-272-4300 PCT OSP: 571-272-7774
---	---