

(19) World Intellectual Property Organization
International Bureau



(43) International Publication Date
22 September 2011 (22.09.2011)

(10) International Publication Number
WO 2011/115866 A1

(51) International Patent Classification:
F02B 33/22 (2006.01)

(21) International Application Number:
PCT/US2011/028274

(22) International Filing Date:
14 March 2011 (14.03.2011)

(25) Filing Language: English

(26) Publication Language: English

(30) Priority Data:
61/313,831 15 March 2010 (15.03.2010) US
61/363,825 13 July 2010 (13.07.2010) US
61/365,343 18 July 2010 (18.07.2010) US

(71) Applicant (for all designated States except US): **SCUD-ERI GROUP, LLC** [US/US]; 1111 Elm Street, Suite 33, West Springfield, MA 01089 (US).

(72) Inventors: **MELDOLESI, Riccardo**; 55 New Road, Shoreham-by-sea, West Sussex BN43 6RB (GB). **BADAIN, Nicholas**; 37 Rosslyn Road, Shoreham-by-sea, West Sussex BN43 6WL (GB). **GILBERT, Ian**; 67 Beach Green, Shoreham-by-sea, West Sussex BN43 5YE (GB).

(74) Agents: **FILDES, Christopher, J.** et al.; Fildes & Outland, P.C., 20916 Mack Avenue, Suite 2, Grosse Pointe Woods, MI 48236 (US).

(81) Designated States (unless otherwise indicated, for every kind of national protection available): AE, AG, AL, AM, AO, AT, AU, AZ, BA, BB, BG, BH, BR, BW, BY, BZ, CA, CH, CL, CN, CO, CR, CU, CZ, DE, DK, DM, DO, DZ, EC, EE, EG, ES, FI, GB, GD, GE, GH, GM, GT, HN, HR, HU, ID, IL, IN, IS, JP, KE, KG, KM, KN, KP, KR, KZ, LA, LC, LK, LR, LS, LT, LU, LY, MA, MD, ME, MG, MK, MN, MW, MX, MY, MZ, NA, NG, NI, NO, NZ, OM, PE, PG, PH, PL, PT, RO, RS, RU, SC, SD,

[Continued on next page]

(54) Title: SPLIT-CYCLE ENGINE WITH HIGH RESIDUAL EXPANSION RATION

FIG. 1

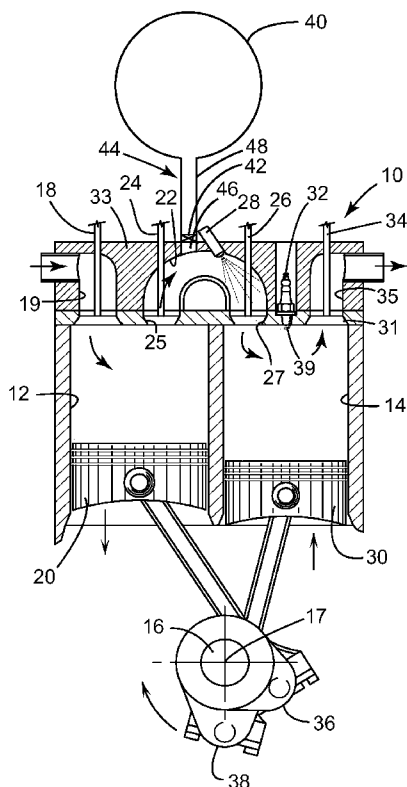

(57) Abstract: An engine includes a rotatable crankshaft. A compression piston is slidably received within a compression cylinder and operatively connected to the crankshaft. An expansion piston is slidably received within an expansion cylinder and operatively connected to the crankshaft. A crossover passage interconnects the compression and expansion cylinders. The crossover passage includes a crossover expansion (XovrE) valve disposed therein. In an Engine Firing (EF) mode of the engine, the engine has a residual expansion ratio at XovrE valve closing of 10.0 to 1 or greater, and more preferably 15.7 to 1 or greater.

WO 2011/115866 A1



SE, SG, SK, SL, SM, ST, SV, SY, TH, TJ, TM, TN, TR, TT, TZ, UA, UG, US, UZ, VC, VN, ZA, ZM, ZW.

EE, ES, FI, FR, GB, GR, HR, HU, IE, IS, IT, LT, LU, LV, MC, MK, MT, NL, NO, PL, PT, RO, RS, SE, SI, SK, SM, TR), OAPI (BF, BJ, CF, CG, CI, CM, GA, GN, GQ, GW, ML, MR, NE, SN, TD, TG).

(84) Designated States (unless otherwise indicated, for every kind of regional protection available): ARIPO (BW, GH, GM, KE, LR, LS, MW, MZ, NA, SD, SL, SZ, TZ, UG, ZM, ZW), Eurasian (AM, AZ, BY, KG, KZ, MD, RU, TJ, TM), European (AL, AT, BE, BG, CH, CY, CZ, DE, DK,

Published:

— with international search report (Art. 21(3))

SPLIT-CYCLE ENGINE WITH HIGH RESIDUAL EXPANSION RATIO**TECHNICAL FIELD**

This invention relates to split-cycle engines and, more particularly, to such an engine having a high residual expansion ratio and optionally incorporating an air-hybrid system.

BACKGROUND OF THE INVENTION

10 For purposes of clarity, the term "conventional engine" as used in the present application refers to an internal combustion engine wherein all four strokes of the well-known Otto cycle (i.e., the intake (or inlet), compression, expansion (or power) and exhaust strokes) are contained in each piston/cylinder combination of the engine. Each stroke requires one half revolution of the crankshaft (180 degrees crank angle (CA)), and two full revolutions of the crankshaft (720 degrees CA) are required to complete the entire Otto cycle in each cylinder of a conventional engine.

20 Also, for purposes of clarity, the following definition is offered for the term "split-cycle engine" as may be applied to engines disclosed in the prior art and as referred to in the present application.

A split-cycle engine as referred to herein comprises:

a crankshaft rotatable about a crankshaft axis;
a compression piston slidably received within a compression cylinder and operatively connected to the crankshaft such that the compression piston reciprocates through an intake stroke and a compression stroke during a single rotation of the crankshaft;

an expansion (power) piston slidably received within an expansion cylinder and operatively connected to the crankshaft such that the expansion piston reciprocates through an expansion stroke and an exhaust stroke during a single rotation of the crankshaft; and

a crossover passage (port) interconnecting the compression and expansion cylinders, the crossover passage including at least a crossover expansion (XovrE) valve disposed therein, but more preferably including a crossover compression (XovrC) valve and a crossover expansion (XovrE) valve defining a pressure chamber therebetween.

United States Patent No. 6,543,225 granted April 8, 2003 to Scuderi and United States Patent No. 6,952,923 granted October 11, 2005 to Branyon et al., both of which are incorporated herein by reference, contain an extensive discussion of split-cycle and similar-type engines. In addition, these patents disclose details of prior versions of an engine of which the present disclosure details further developments.

Split-cycle air-hybrid engines combine a split-cycle engine with an air reservoir and various controls. This combination enables a split-cycle air-hybrid engine to store energy in the form of compressed air in the air reservoir. The compressed air in the air reservoir is later used in the expansion cylinder to power the crankshaft.

A split-cycle air-hybrid engine as referred to herein comprises:

a crankshaft rotatable about a crankshaft axis;
a compression piston slidably received within a compression cylinder and operatively connected to the crankshaft such that the compression piston reciprocates through an intake stroke and a compression stroke during a single rotation of the crankshaft;

an expansion (power) piston slidably received within an expansion cylinder and operatively connected to the crankshaft such that the expansion piston reciprocates through an expansion stroke and an exhaust stroke during a single rotation of the crankshaft;

a crossover passage (port) interconnecting the compression and expansion cylinders, the crossover passage including at least a crossover expansion (XovrE) valve disposed therein, but more preferably including a crossover compression (XovrC) valve and a crossover expansion (XovrE) valve defining a pressure chamber therebetween; and

an air reservoir operatively connected to the crossover passage and selectively operable to store compressed air from the compression cylinder and to deliver compressed air to the expansion cylinder.

United States Patent No. 7,353,786 granted April 8, 2008 to Scuderi et al., which is incorporated herein by reference, contains an extensive discussion of split-cycle air-hybrid and similar-type engines. In addition, this patent discloses details of prior hybrid systems of which the present disclosure details further developments.

A split-cycle air-hybrid engine can be run in a normal operating or firing (NF) mode (also commonly called the Engine Firing (EF) mode) and four basic air-hybrid modes. In the EF mode, the engine functions as a non-air hybrid split-cycle engine, operating without the use of its air reservoir. In the EF mode, a tank valve operatively connecting the crossover passage to the air reservoir remains closed to isolate the air reservoir from the basic split-cycle engine.

The split-cycle air-hybrid engine operates with the use of its air reservoir in four hybrid modes. The four hybrid modes are:

- 1) Air Expander (AE) mode, which includes using compressed air energy from the air reservoir without combustion;
- 2) Air Compressor (AC) mode, which includes storing compressed air energy into the air reservoir without combustion;
- 3) Air Expander and Firing (AEF) mode, which includes using compressed air energy from the air reservoir with combustion; and
- 4) Firing and Charging (FC) mode, which includes storing compressed air energy into the air reservoir with combustion.

However, further optimization of these modes, EF, AE, AC, AEF and FC, is desirable to enhance efficiency and reduce emissions.

SUMMARY OF THE INVENTION

The present invention provides a split-cycle engine in which the use of the Engine Firing (EF) mode is optimized for potentially any vehicle in any drive cycle for improved efficiency.

More particularly, an exemplary embodiment of an engine in accordance with the present invention includes a crankshaft rotatable about a crankshaft axis. A compression piston is slidably received within a compression cylinder and operatively connected to the crankshaft such that the compression piston reciprocates through an intake stroke and a compression stroke during a single rotation of the crankshaft. An expansion piston is slidably received within an expansion cylinder and operatively connected to the crankshaft such that the expansion piston reciprocates through an expansion stroke and an exhaust stroke during a

single rotation of the crankshaft. A crossover passage interconnects the compression and expansion cylinders. The crossover passage includes a crossover expansion (XovrE) valve disposed therein. The engine is operable in an Engine Firing (EF) mode. In the EF mode, the engine has a residual expansion ratio at XovrE valve closing of 10.0 to 1 or greater, and more preferably 15.7 to 1 or greater.

A method of operating an engine is also disclosed. The engine includes a crankshaft rotatable about a crankshaft axis. A compression piston is slidably received within a compression cylinder and operatively connected to the crankshaft such that the compression piston reciprocates through an intake stroke and a compression stroke during a single rotation of the crankshaft. An expansion piston is slidably received within an expansion cylinder and operatively connected to the crankshaft such that the expansion piston reciprocates through an expansion stroke and an exhaust stroke during a single rotation of the crankshaft. A crossover passage interconnects the compression and expansion cylinders. The crossover passage includes a crossover expansion (XovrE) valve disposed therein. The engine is operable in an Engine Firing (EF) mode. The method in accordance with the present invention includes the following steps: drawing in and compressing inlet air with the compression piston; admitting compressed air from the compression cylinder into the expansion cylinder with fuel, at the beginning of an expansion stroke, the fuel being ignited, burned and expanded on the same expansion stroke of the expansion piston, transmitting power to the crankshaft, and the combustion products being discharged on the exhaust stroke; and maintaining a residual expansion ratio at XovrE valve closing of 10.0 to 1 or greater, more preferably 15.7 to 1 or greater.

These and other features and advantages of the invention will be more fully understood from the following detailed description of the invention taken together with the accompanying drawings.

5

BRIEF DESCRIPTION OF THE DRAWINGS

In the drawings:

FIG. 1 is a lateral sectional view of an exemplary split-cycle air-hybrid engine in accordance with the present invention;

FIG. 2 is a graphical illustration of a preferred exemplary range of residual expansion ratio (i.e., effective volumetric expansion ratio) versus closing angle of a crossover expansion (XovrE) valve in accordance with the present invention;

FIG. 3 is a graphical illustration of inlet valve opening timing with respect to engine speed and load;

FIG. 4 is a graphical illustration of inlet valve closing timing with respect to engine speed and load;

FIG. 5 is a graphical illustration of inlet valve duration with respect to engine speed and load;

FIG. 6 is a graphical illustration of crossover compression (XovrC) valve opening timing with respect to engine speed and load;

FIG. 7 is a graphical illustration of XovrC valve closing timing with respect to engine speed and load;

FIG. 8 is a graphical illustration of XovrC valve duration with respect to engine speed and load;

FIG. 9 is a graphical illustration of XovrE valve opening timing with respect to engine speed and load;

FIG. 10 is a graphical illustration of XovrE valve closing timing with respect to engine speed and load;

30

FIG. 11 is a graphical illustration of XovrE valve duration with respect to engine speed and load;

FIG. 12 is a graphical illustration of exhaust valve opening timing with respect to engine speed and load;

5 FIG. 13 is a graphical illustration of exhaust valve closing timing with respect to engine speed and load; and

FIG. 14 is a graphical illustration of exhaust valve duration with respect to engine speed and load.

10

DETAILED DESCRIPTION OF THE INVENTION

The following glossary of acronyms and definitions of terms is provided for reference.

15 In General

Unless otherwise specified, all valve opening and closing timings are measured in crank angle degrees after top dead center of the expansion piston (ATDCe).

20 Unless otherwise specified, all valve durations are in crank angle degrees (CA).

Air tank (or air storage tank): Storage tank for compressed air.

ATDCe: After top dead center of the expansion piston.

Bar: Unit of pressure, $1 \text{ bar} = 10^5 \text{ N/m}^2$

25 BMEP: Brake mean effective pressure. The term "Brake" refers to the output as delivered to the crankshaft (or output shaft), after friction losses (FMPEP) are accounted for. Brake Mean Effective Pressure (BMEP) is the engine's brake torque output expressed in terms of a mean effective
30 pressure (MEP) value. BMEP is equal to the brake torque divided by engine displacement. This is the performance parameter taken after the losses due to friction. Accordingly, $\text{BMEP} = \text{IMEP} - \text{friction}$. Friction, in this case is

usually also expressed in terms of an MEP value known as Frictional Mean Effective Pressure (or FMEP).

Compressor: The compression cylinder and its associated compression piston of a split-cycle engine.

5 Exhaust (or EXH) duration: Exhaust valve duration.

Exhaust (or EXH) valve: Valve controlling outlet of gas from the expander cylinder.

Expander: The expansion cylinder and its associated expansion piston of a split-cycle engine.

10 IMEP: Indicated Mean Effective Pressure. The term "Indicated" refers to the output as delivered to the top of the piston, before friction losses (FMEP) are accounted for.

RPM: Revolutions Per Minute.

15 Tank valve: Valve connecting the Xovr passage with the compressed air storage tank.

Valve duration: The interval in crank degrees between start of valve opening and end of valve closing.

20 VVA: Variable valve actuation. A mechanism or method operable to alter the shape or timing of a valve's lift profile.

Xovr (or Xover) valve, passage or port: The crossover valves, passages, and/or ports which connect the compression and expansion cylinders through which gas flows from compression to expansion cylinder.

25 XovrC (or XoverC) valves: Valves at the compressor end of the Xovr passage.

XovrC Duration: The interval in crank degrees between start of XovrC valve opening and end of XovrC valve closing.

30 XovrE (or XoverE) valves: Valves at the expander end of the crossover (Xovr) passage.

XovrE duration: The interval in crank degrees between start of XovrE valve opening and end of XovrE valve closing.

Referring to FIG. 1, an exemplary split-cycle air-hybrid engine is shown generally by numeral 10. The split-cycle air-hybrid engine 10 replaces two adjacent cylinders of a conventional engine with a combination of one compression cylinder 12 and one expansion cylinder 14. A cylinder head 33 is typically disposed over an open end of the expansion and compression cylinders 12, 14 to cover and seal the cylinders.

The four strokes of the Otto cycle are "split" over the two cylinders 12 and 14 such that the compression cylinder 12, together with its associated compression piston 20, perform the intake and compression strokes, and the expansion cylinder 14, together with its associated expansion piston 30, perform the expansion and exhaust strokes. The Otto cycle is therefore completed in these two cylinders 12, 14 once per crankshaft 16 revolution (360 degrees CA) about crankshaft axis 17.

During the intake stroke, intake air is drawn into the compression cylinder 12 through an intake port 19 disposed in the cylinder head 33. An inwardly opening (opening inwardly into the cylinder and toward the piston) poppet intake valve 18 controls fluid communication between the intake port 19 and the compression cylinder 12.

During the compression stroke, the compression piston 20 pressurizes the air charge and drives the air charge into the crossover passage (or port) 22, which is typically disposed in the cylinder head 33. This means that the compression cylinder 12 and compression piston 20 are a source of high-pressure gas to the crossover passage 22, which acts as the intake passage for the expansion cylinder 14. In some embodiments, two or more crossover passages 22 interconnect the compression cylinder 12 and the expansion cylinder 14.

The geometric (or volumetric) compression ratio of the compression cylinder 12 of split-cycle engine 10 (and for split-cycle engines in general) is herein commonly referred to as the "compression ratio" of the split-cycle engine. The geometric (or volumetric) compression ratio of the expansion cylinder 14 of split-cycle engine 10 (and for split-cycle engines in general) is herein commonly referred to as the "expansion ratio" of the split-cycle engine. The geometric compression ratio of a cylinder is well known in the art as the ratio of the enclosed (or trapped) volume in the cylinder (including all recesses) when a piston reciprocating therein is at its bottom dead center (BDC) position to the enclosed volume (i.e., clearance volume) in the cylinder when said piston is at its top dead center (TDC) position. Specifically for split-cycle engines as defined herein, the compression ratio of a compression cylinder is determined when the XovrC valve is closed. Also specifically for split-cycle engines as defined herein, the expansion ratio of an expansion cylinder is determined when the XovrE valve is closed.

Due to very high compression ratios (e.g., 20 to 1, 30 to 1, 40 to 1, or greater) within the compression cylinder 12, an outwardly opening (opening outwardly away from the cylinder and piston) poppet crossover compression (XovrC) valve 24 at the crossover passage inlet 25 is used to control flow from the compression cylinder 12 into the crossover passage 22. Due to very high expansion ratios (e.g., 20 to 1, 30 to 1, 40 to 1, or greater) within the expansion cylinder 14, an outwardly opening poppet crossover expansion (XovrE) valve 26 at the outlet 27 of the crossover passage 22 controls flow from the crossover passage 22 into the expansion cylinder 14. The actuation rates and phasing of the XovrC and XovrE valves 24, 26 are timed to maintain

pressure in the crossover passage 22 at a high minimum pressure (typically 20 bar or higher at full load) during all four strokes of the Otto cycle.

At least one fuel injector 28 injects fuel into
5 the pressurized air at the exit end of the crossover passage 22 in correspondence with the XovrE valve 26 opening, which occurs shortly before expansion piston 30 reaches its top dead center position. The air/fuel charge enters the expansion cylinder 14 when expansion piston 30 is close to
10 its top dead center position. As piston 30 begins its descent from its top dead center position, and while the XovrE valve 26 is still open, spark plug 32, which includes a spark plug tip 39 that protrudes into cylinder 14, is fired to initiate combustion in the region around the spark
15 plug tip 39. Combustion can be initiated while the expansion piston is between 1 and 30 degrees CA past its top dead center (TDC) position. More preferably, combustion can be initiated while the expansion piston is between 5 and 25 degrees CA past its top dead center (TDC) position. Most
20 preferably, combustion can be initiated while the expansion piston is between 10 and 20 degrees CA past its top dead center (TDC) position. Additionally, combustion may be initiated through other ignition devices and/or methods, such as with glow plugs, microwave ignition devices or
25 through compression ignition methods.

During the exhaust stroke, exhaust gases are pumped out of the expansion cylinder 14 through exhaust port 35 disposed in cylinder head 33. An inwardly opening poppet exhaust valve 34, disposed in the inlet 31 of the exhaust
30 port 35, controls fluid communication between the expansion cylinder 14 and the exhaust port 35. The exhaust valve 34 and the exhaust port 35 are separate from the crossover passage 22. That is, exhaust valve 34 and the exhaust port

35 do not make contact with, or are not disposed in, the crossover passage 22.

With the split-cycle engine concept, the geometric engine parameters (i.e., bore, stroke, connecting rod length, volumetric compression ratio, etc.) of the compression 12 and expansion 14 cylinders are generally independent from one another. For example, the crank throws 36, 38 for the compression cylinder 12 and expansion cylinder 14, respectively, may have different radii and may be phased apart from one another such that top dead center (TDC) of the expansion piston 30 occurs prior to TDC of the compression piston 20. This independence enables the split-cycle engine 10 to potentially achieve higher efficiency levels and greater torques than typical four-stroke engines.

The geometric independence of engine parameters in the split-cycle engine 10 is also one of the main reasons why pressure can be maintained in the crossover passage 22 as discussed earlier. Specifically, the expansion piston 30 reaches its top dead center position prior to the compression piston reaching its top dead center position by a discreet phase angle (typically between 10 and 30 crank angle degrees). This phase angle, together with proper timing of the XovrC valve 24 and the XovrE valve 26, enables the split-cycle engine 10 to maintain pressure in the crossover passage 22 at a high minimum pressure (typically 20 bar absolute or higher during full load operation) during all four strokes of its pressure/volume cycle. That is, the split-cycle engine 10 is operable to time the XovrC valve 24 and the XovrE valve 26 such that the XovrC and XovrE valves are both open for a substantial period of time (or period of crankshaft rotation) during which the expansion piston 30 descends from its TDC position towards its BDC position and the compression piston 20 simultaneously ascends from its

BDC position towards its TDC position. During the period of time (or crankshaft rotation) that the crossover valves 24, 26 are both open, a substantially equal mass of air is transferred (1) from the compression cylinder 12 into the crossover passage 22 and (2) from the crossover passage 22 to the expansion cylinder 14. Accordingly, during this period, the pressure in the crossover passage is prevented from dropping below a predetermined minimum pressure (typically 20, 30, or 40 bar absolute during full load operation). Moreover, during a substantial portion of the engine cycle (typically 80% of the entire engine cycle or greater), the XovrC valve 24 and XovrE valve 26 are both closed to maintain the mass of trapped gas in the crossover passage 22 at a substantially constant level. As a result, the pressure in the crossover passage 22 is maintained at a predetermined minimum pressure during all four strokes of the engine's pressure/volume cycle.

For purposes herein, the method of having the XovrC 24 and XovrE 26 valves open while the expansion piston 30 is descending from TDC and the compression piston 20 is ascending toward TDC in order to simultaneously transfer a substantially equal mass of gas into and out of the crossover passage 22 is referred to herein as the Push-Pull method of gas transfer. It is the Push-Pull method that enables the pressure in the crossover passage 22 of the split-cycle engine 10 to be maintained at typically 20 bar or higher during all four strokes of the engine's cycle when the engine is operating at full load.

As discussed earlier, the exhaust valve 34 is disposed in the exhaust port 35 of the cylinder head 33 separate from the crossover passage 22. The structural arrangement of the exhaust valve 34 not being disposed in the crossover passage 22, and therefore the exhaust port 35

not sharing any common portion with the crossover passage 22, is preferred in order to maintain the trapped mass of gas in the crossover passage 22 during the exhaust stroke. Accordingly, large cyclic drops in pressure are prevented which may force the pressure in the crossover passage below the predetermined minimum pressure.

XovrE valve 26 opens shortly before the expansion piston 30 reaches its top dead center position. At this time, the pressure ratio of the pressure in crossover passage 22 to the pressure in expansion cylinder 14 is high, due to the fact that the minimum pressure in the crossover passage is typically 20 bar absolute or higher and the pressure in the expansion cylinder during the exhaust stroke is typically about one to two bar absolute. In other words, when XovrE valve 26 opens, the pressure in crossover passage 22 is substantially higher than the pressure in expansion cylinder 14 (typically in the order of 20 to 1 or greater). This high pressure ratio causes initial flow of the air and/or fuel charge to flow into expansion cylinder 14 at high speeds. These high flow speeds can reach the speed of sound, which is referred to as sonic flow. This sonic flow is particularly advantageous to split-cycle engine 10 because it causes a rapid combustion event, which enables the split-cycle engine 10 to maintain high combustion pressures even though ignition is initiated while the expansion piston 30 is descending from its top dead center position.

The split-cycle air-hybrid engine 10 also includes an air reservoir (tank) 40, which is operatively connected to the crossover passage 22 by an air reservoir (tank) valve 42. Embodiments with two or more crossover passages 22 may include a tank valve 42 for each crossover passage 22, which connect to a common air reservoir 40, or alternatively each

crossover passage 22 may operatively connect to separate air reservoirs 40.

The tank valve 42 is typically disposed in an air reservoir (tank) port 44, which extends from crossover passage 22 to the air tank 40. The air tank port 44 is divided into a first air reservoir (tank) port section 46 and a second air reservoir (tank) port section 48. The first air tank port section 46 connects the air tank valve 42 to the crossover passage 22, and the second air tank port section 48 connects the air tank valve 42 to the air tank 40. The volume of the first air tank port section 46 includes the volume of all additional ports and recesses which connect the tank valve 42 to the crossover passage 22 when the tank valve 42 is closed.

The tank valve 42 may be any suitable valve device or system. For example, the tank valve 42 may be an active valve which is activated by various valve actuation devices (e.g., pneumatic, hydraulic, cam, electric or the like). Additionally, the tank valve 42 may comprise a tank valve system with two or more valves actuated with two or more actuation devices.

Air tank 40 is utilized to store energy in the form of compressed air and to later use that compressed air to power the crankshaft 16, as described in the aforementioned United States Patent No. 7,353,786 to Scuderi et al. This mechanical means for storing potential energy provides numerous potential advantages over the current state of the art. For instance, the split-cycle engine can potentially provide many advantages in fuel efficiency gains and NOx emissions reduction at relatively low manufacturing and waste disposal costs in relation to other technologies on the market, such as diesel engines and electric-hybrid systems.

By selectively controlling the opening and/or closing of the air tank valve 42 and thereby controlling communication of the air tank 40 with the crossover passage 22, the split-cycle air-hybrid engine 10 is operable in an Engine Firing (EF) mode, an Air Expander (AE) mode, an Air Compressor (AC) mode, an Air Expander and Firing (AEF) mode, and a Firing and Charging (FC) mode. The EF mode is a non-hybrid mode in which the engine operates as described above without the use of the air tank 40. The AC and FC modes are energy storage modes. The AC mode is an air-hybrid operating mode in which compressed air is stored in the air tank 40 without combustion occurring in the expansion cylinder 14 (i.e., no fuel expenditure), such as by utilizing the kinetic energy of a vehicle including the engine 10 during braking. The FC mode is an air-hybrid operating mode in which excess compressed air not needed for combustion is stored in the air tank 40, such as at less than full engine load (e.g., engine idle, vehicle cruising at constant speed). The storage of compressed air in the FC mode has an energy cost (penalty); therefore, it is desirable to have a net gain when the compressed air is used at a later time. The AE and AEF modes are stored energy usage modes. The AE mode is an air-hybrid operating mode in which compressed air stored in the air tank 40 is used to drive the expansion piston 30 without combustion occurring in the expansion cylinder 14 (i.e., no fuel expenditure). The AEF mode is an air-hybrid operating mode in which compressed air stored in the air tank 40 is utilized in the expansion cylinder 14 for combustion.

In the EF mode, the air tank valve 42 is kept closed through the entire rotation of the crankshaft 16 to isolate the air tank 40 from the rest of the engine 10. Thus, compressed air is not received in the air tank 40 nor

is stored compressed air released from the air tank. The compression piston 20 and expansion piston 30 are in their respective compression and power modes, in that the compression piston 20 draws in and compresses inlet air for use in the expansion cylinder 14, and compressed air is admitted to the expansion cylinder 14 with fuel, at the beginning of an expansion stroke, which is ignited, burned and expanded on the same expansion stroke of the expansion piston 30, transmitting power to the crankshaft 16, and the combustion products are discharged on the exhaust stroke.

The timing of the XovrE valve 26 closing at the beginning of the expansion stroke (as the expansion piston 30 descends from top dead center) is significant to the efficiency of the engine 10 in the EF mode. This is because, when the XovrE valve 26 is open, the volume of the crossover passage 22 is part of the clearance space above the piston wherein combustion takes place. Yet virtually all of the fuel is in the expansion cylinder 14, and none of it is in the crossover passage 22. Once the XovrE valve 26 is closed, the entire combustion process is confined to the expansion cylinder 14, and the expanding combusting mass of fuel and air can most effectively do work upon the piston 30.

The later the XovrE valve 26 closes, the smaller the residual (i.e., effective volumetric) expansion ratio, which is defined as the ratio (a/b) of (a) the trapped volume in the expansion cylinder 14 (i.e., the volume of a chamber generally defined by the cylinder 14 wall, the top of the expansion piston 30, and the bottom of the cylinder head 33) when the expansion piston 30 is at bottom dead center to (b) the trapped volume in the expansion cylinder 14 at the time just when the XovrE valve 26 closes. Once the XovrE valve 26 is closed during the expansion stroke of

the expansion piston 30, the expanding trapped mass is present solely in the expansion cylinder 14 and work is produced as the mass expands. Clearly, the later the XovrE valve 26 closes, the farther the expansion piston 30 is from top dead center, thus the smaller the residual expansion ratio and the less work that is produced during the expansion stroke.

As shown in FIG. 2, to avoid significant deterioration in engine efficiency in the EF mode, the residual expansion ratio should be 10.0:1 or greater. More preferably, the residual expansion ratio should be 15.7:1 or greater. In this exemplary embodiment, in order to achieve a residual expansion ratio of 10:1 or greater, the XovrE valve should be closed at approximately 30 degrees or less ATDCe, and more preferably should be closed at 22 degrees or less ATDCe.

FIGS. 3 through 14 are graphical illustrations of exemplary valve timings and durations (time from opening to closing) across a range of engine speeds (1000 to 4000 rpm) and engine loads (1 to 5 bar IMEP). For example, at approximately 2500 rpm and 3 bar IMEP: (i) the inlet valve 18 is opened at about 36 degrees ATDCe and closed at about 102 degrees ATDCe resulting in a inlet valve open duration of about 66 degrees; (ii) the XovrC valve 24 is opened at about -18 degrees ATDCe and closed at about 24 degrees ATDCe resulting in a XovrC valve open duration of about 42 degrees; (iii) the XovrE valve 26 is opened at about -14 degrees ATDCe and closed at about 22 degrees ATDCe resulting in a XovrE valve open duration of about 36 degrees; and (iv) the exhaust valve 34 is opened at about 148 degrees ATDCe and closed at about -13 degrees ATDCe resulting in an exhaust valve open duration of about 199 degrees.

Although the invention has been described by reference to a specific embodiment, it should be understood that numerous changes may be made within the spirit and scope of the inventive concepts described. Accordingly, it is intended that the invention not be limited to the described embodiment, but that it have the full scope defined by the language of the following claims.

CLAIMS

What is claimed is:

1. An engine comprising:

5 a crankshaft rotatable about a crankshaft axis;
a compression piston slidably received within a
compression cylinder and operatively connected to the
crankshaft such that the compression piston reciprocates
through an intake stroke and a compression stroke during a
10 single rotation of the crankshaft;

an expansion piston slidably received within an
expansion cylinder and operatively connected to the
crankshaft such that the expansion piston reciprocates
through an expansion stroke and an exhaust stroke during a
15 single rotation of the crankshaft; and

a crossover passage interconnecting the
compression and expansion cylinders, the crossover passage
including a crossover expansion (XovrE) valve disposed
therein;

20 the engine being operable in an Engine Firing (EF)
mode, wherein, in the EF mode, the engine has a residual
expansion ratio at XovrE valve closing of 10.0 to 1 or
greater.

25 2. The engine of claim 1, wherein, in the EF
mode, the residual expansion ratio at XovrE valve closing is
15.7 to 1 or greater.

3. The engine of claim 1, wherein, in the EF
mode, the XovrE valve is closed at 30 degrees or less after
top dead center of the expansion piston (ATDCe).

30 4. The engine of claim 1, wherein, in the EF
mode, the XovrE valve is closed at 22 degrees or less after
top dead center of the expansion piston (ATDCe).

5 5. The engine of claim 1, wherein the crossover passage includes a crossover compression (XovrC) valve disposed therein, the crossover compression (XovrC) valve and the crossover expansion (XovrE) valve defining a pressure chamber therebetween.

 6. The engine of claim 5, including:

 an air reservoir operatively connected to the crossover passage and selectively operable to store compressed air from the compression cylinder and to deliver compressed air to the expansion cylinder; and

 an air reservoir valve selectively controlling air flow into and out of the air reservoir, wherein, in the EF mode, the air reservoir valve is closed.

 7. The engine of claim 1, wherein, in the EF mode, the compression piston draws in and compresses inlet air for use in the expansion cylinder, and compressed air is admitted to the expansion cylinder with fuel, at the beginning of an expansion stroke, which is ignited, burned and expanded on the same expansion stroke of the expansion piston, transmitting power to the crankshaft, and the combustion products are discharged on the exhaust stroke.

 8. A method of operating an engine including:

 a crankshaft rotatable about a crankshaft axis;

 a compression piston slidably received within a compression cylinder and operatively connected to the crankshaft such that the compression piston reciprocates through an intake stroke and a compression stroke during a single rotation of the crankshaft;

 an expansion piston slidably received within an expansion cylinder and operatively connected to the crankshaft such that the expansion piston reciprocates through an expansion stroke and an exhaust stroke during a single rotation of the crankshaft; and

a crossover passage interconnecting the compression and expansion cylinders, the crossover passage including a crossover expansion (XovrE) valve disposed therein;

5 the engine being operable in an Engine Firing (EF) mode;

the method including the steps of:

drawing in and compressing inlet air with the compression piston;

10 admitting compressed air from the compression cylinder into the expansion cylinder with fuel, at the beginning of an expansion stroke, the fuel being ignited, burned and expanded on the same expansion stroke of the expansion piston, transmitting power to the crankshaft, and
15 the combustion products being discharged on the exhaust stroke; and

maintaining a residual expansion ratio at XovrE valve closing of 10.0 to 1 or greater.

9. The method of claim 8, including the step of
20 maintaining the residual expansion ratio at XovrE valve closing at 15.7 to 1 or greater.

10. The method of claim 8, including the step of closing the XovrE valve at 30 degrees or less after top dead center of the expansion piston (ATDCE).

25 11. The method of claim 8, including the step of closing the XovrE valve at 22 degrees or less after top dead center of the expansion piston (ATDCE).

12. The method of claim 8, wherein the engine includes a crossover compression (XovrC) valve disposed
30 therein, the crossover compression (XovrC) valve and the crossover expansion (XovrE) valve defining a pressure chamber therebetween, an air reservoir operatively connected to the crossover passage and selectively operable to store

compressed air from the compression cylinder and to deliver compressed air to the expansion cylinder, and an air reservoir valve selectively controlling air flow into and out of the air reservoir; and

5 the method further includes the step of keeping the air reservoir valve closed when the engine is operated in the EF mode.

FIG. 1

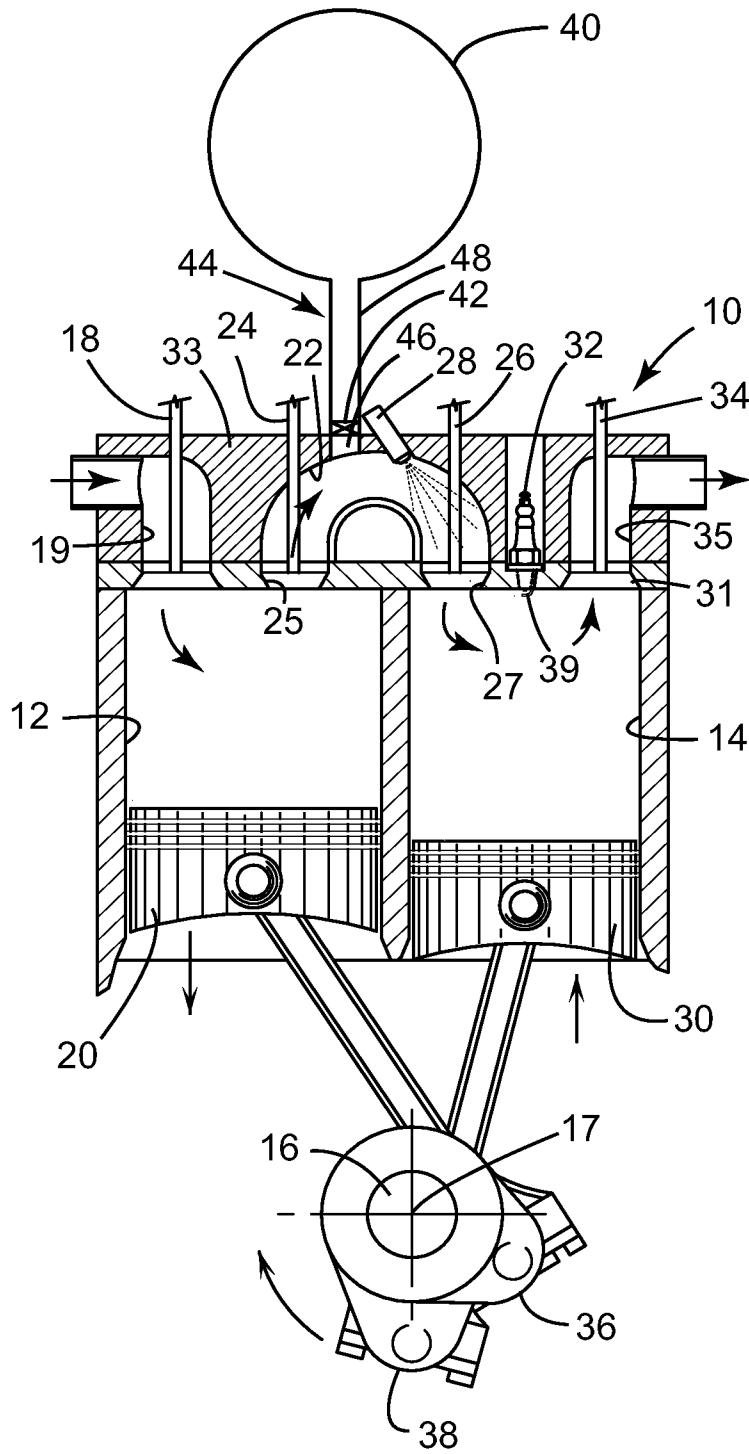

FIG. 2

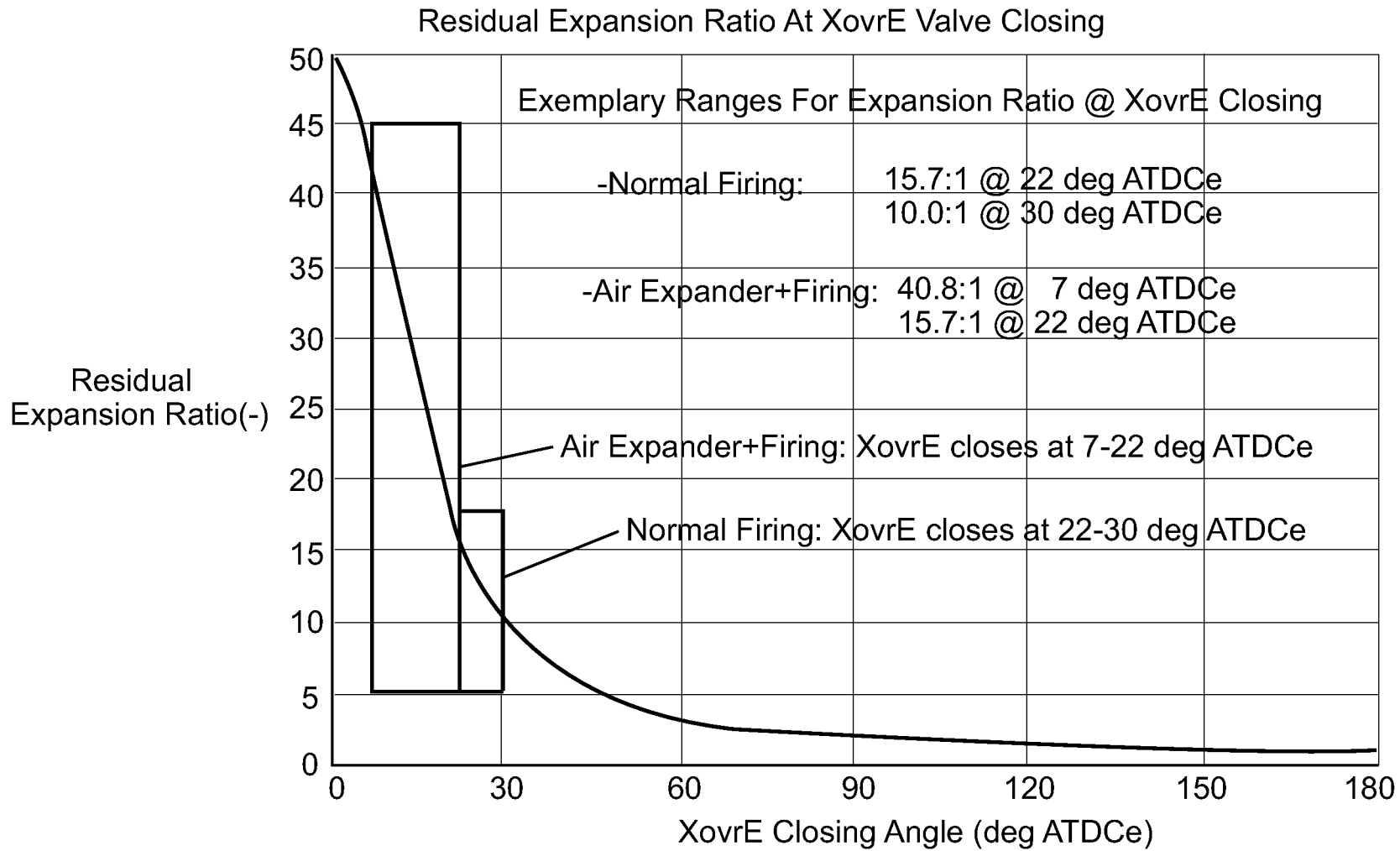

FIG. 3

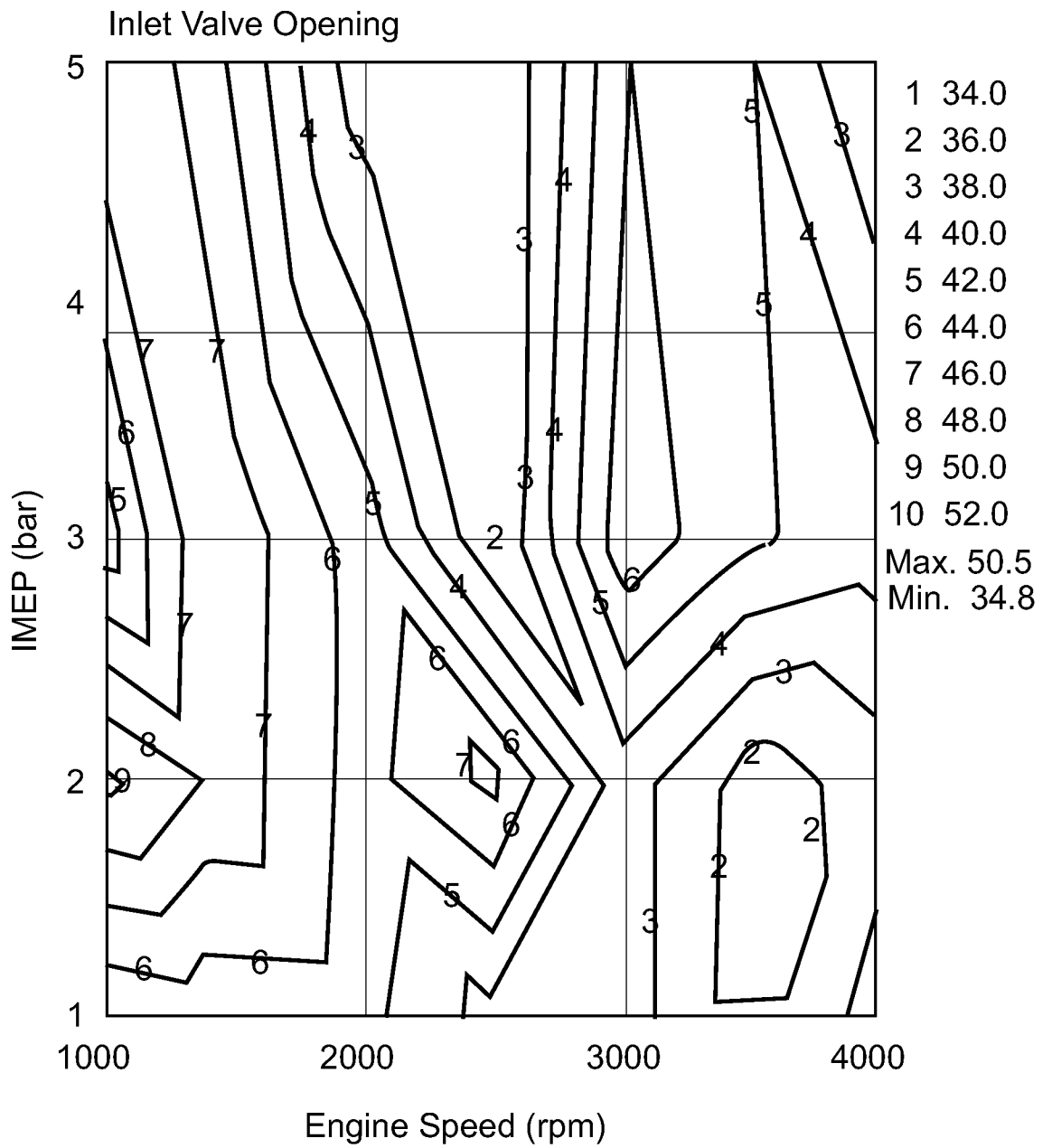
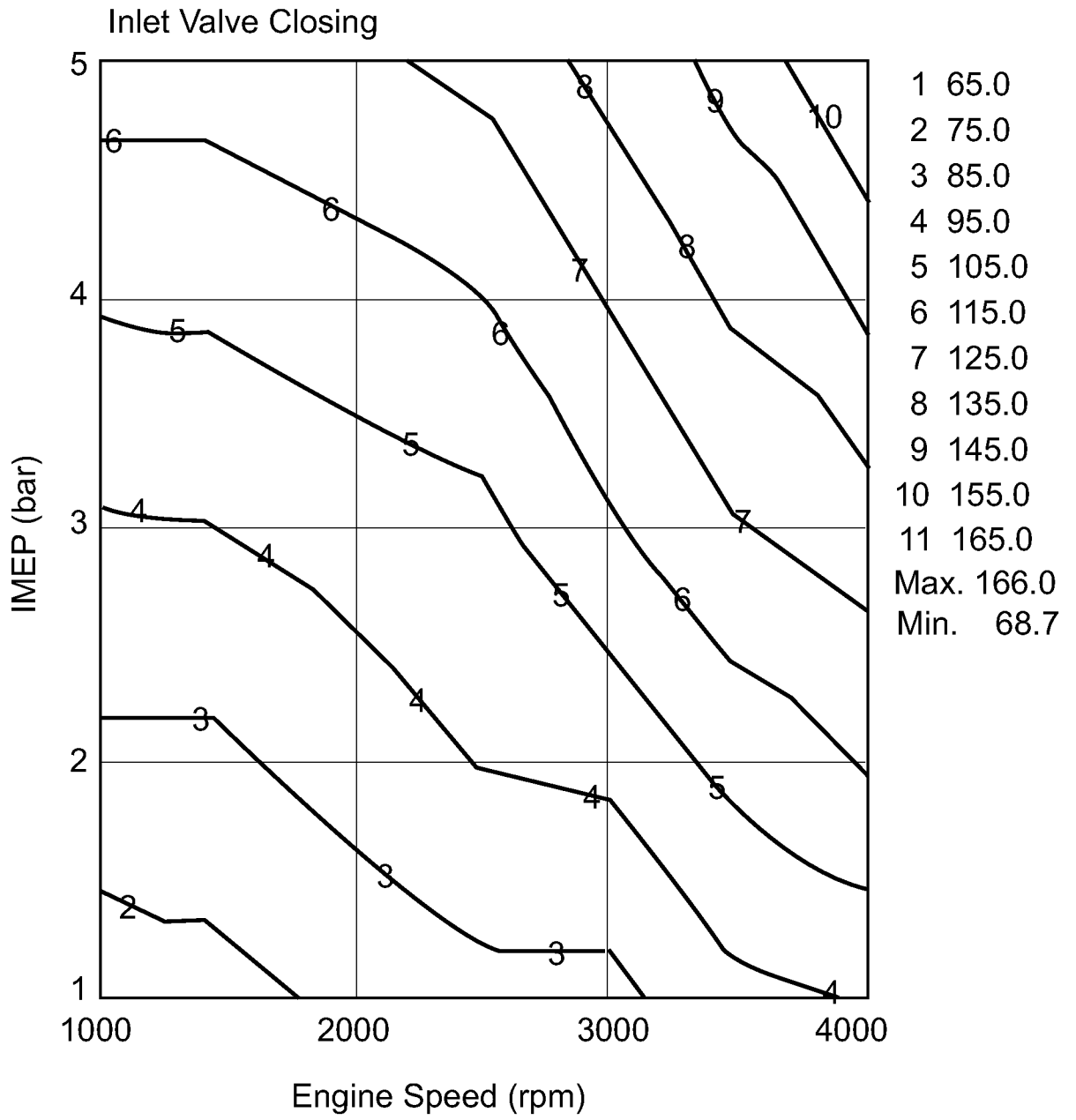
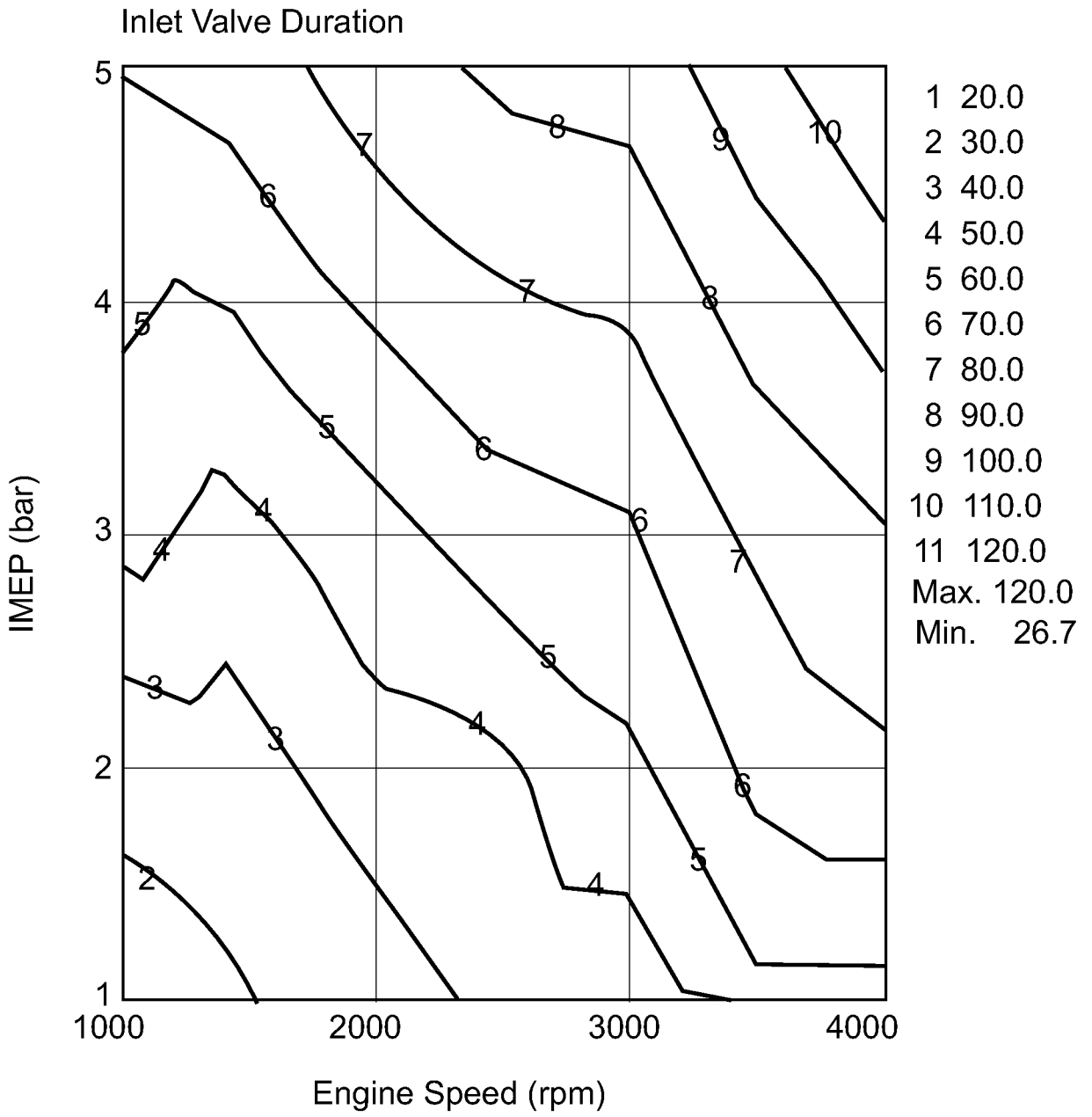

FIG. 4



5/14

FIG. 5



6/14

FIG. 6

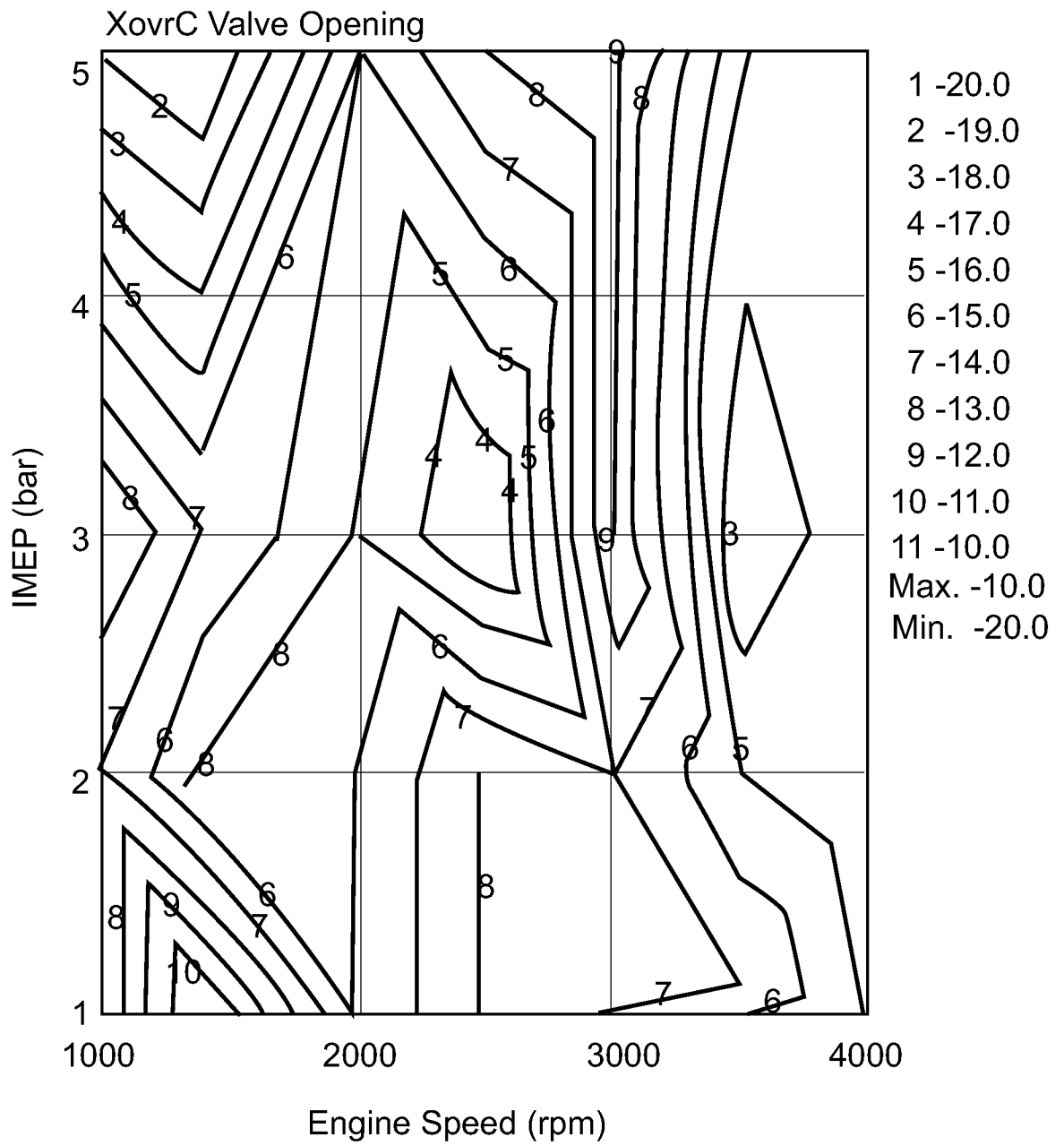

7/14

FIG. 7

XovrC Valve Closing

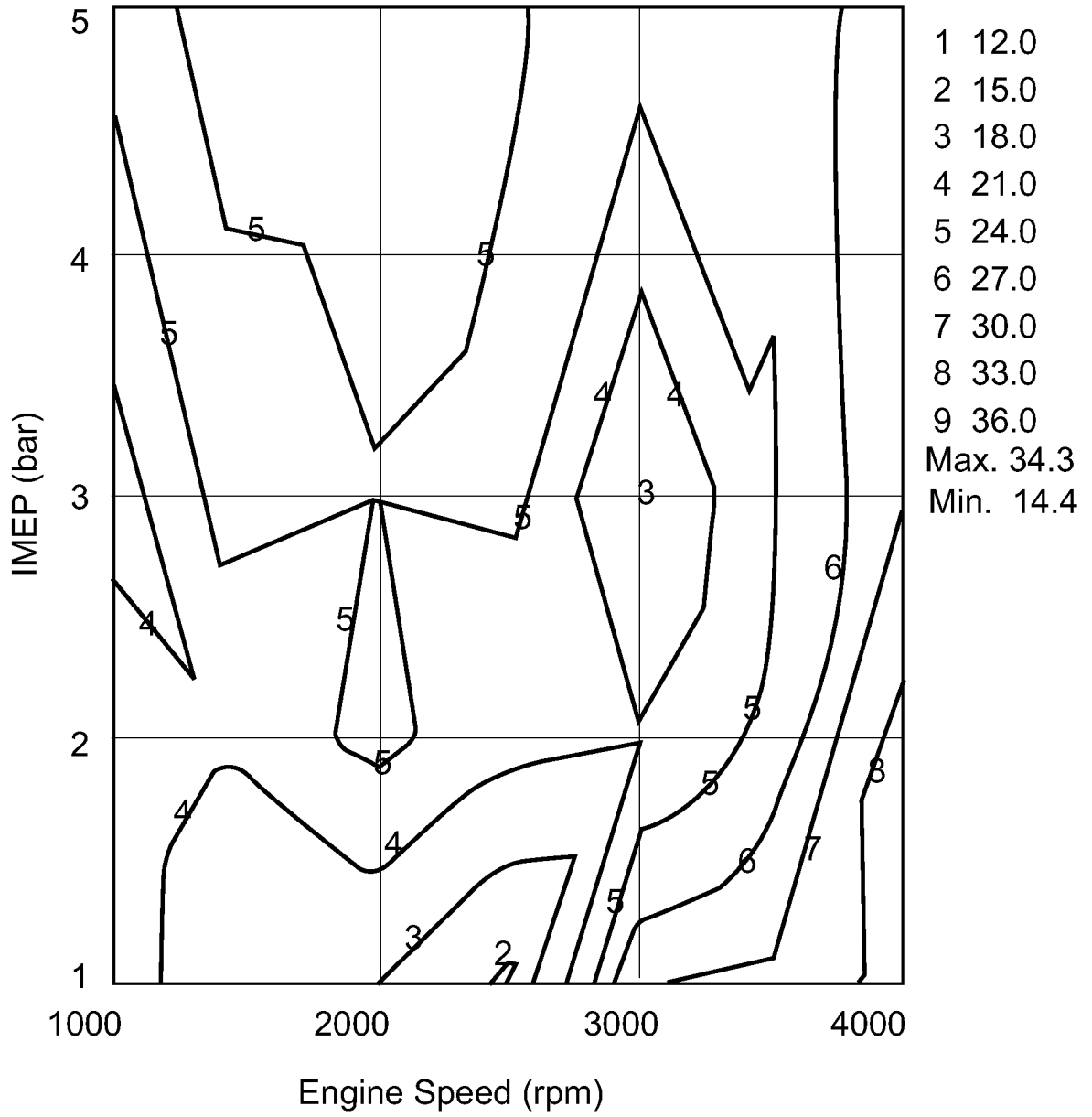

8/14

FIG. 8

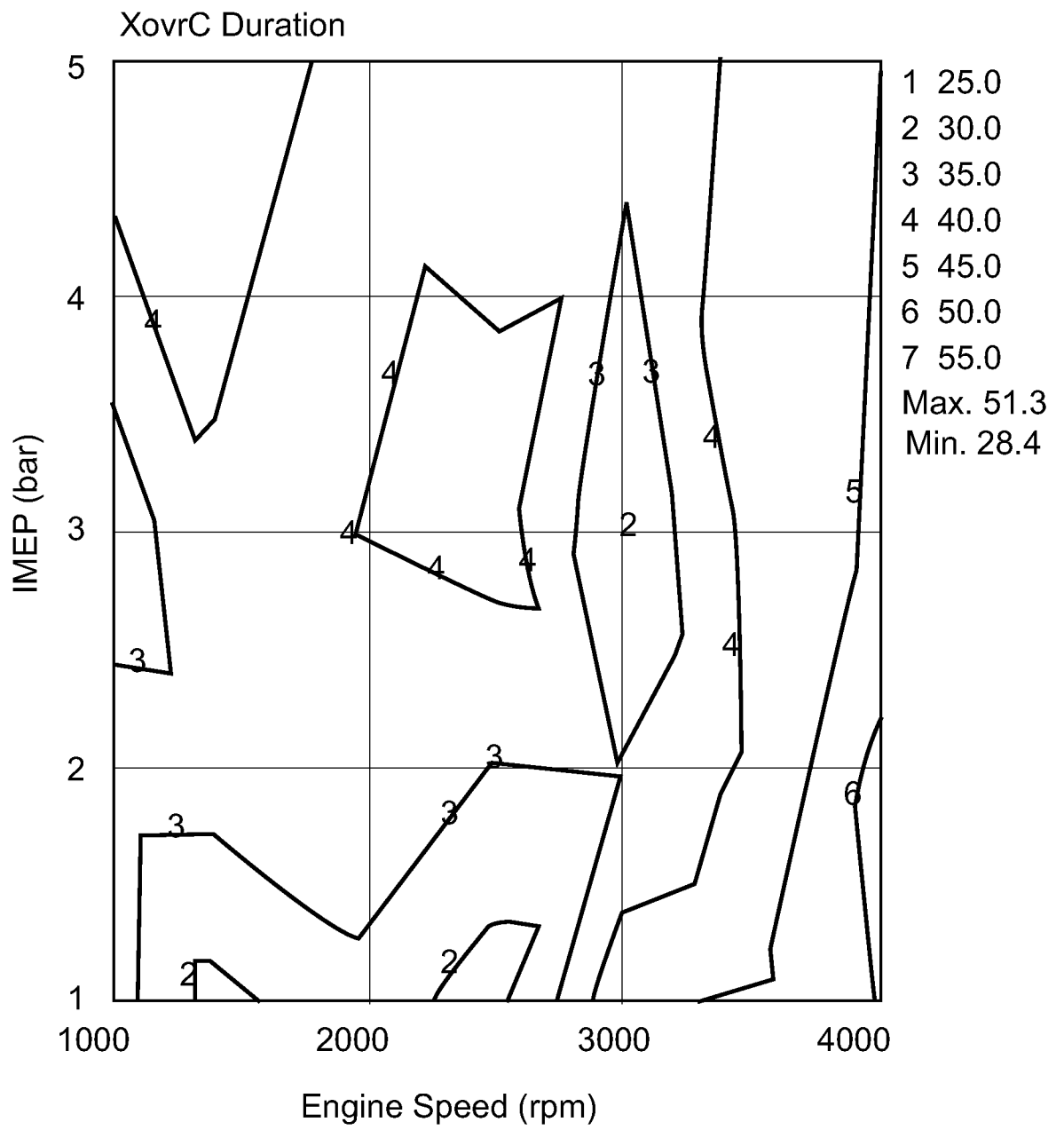

9/14

FIG. 9

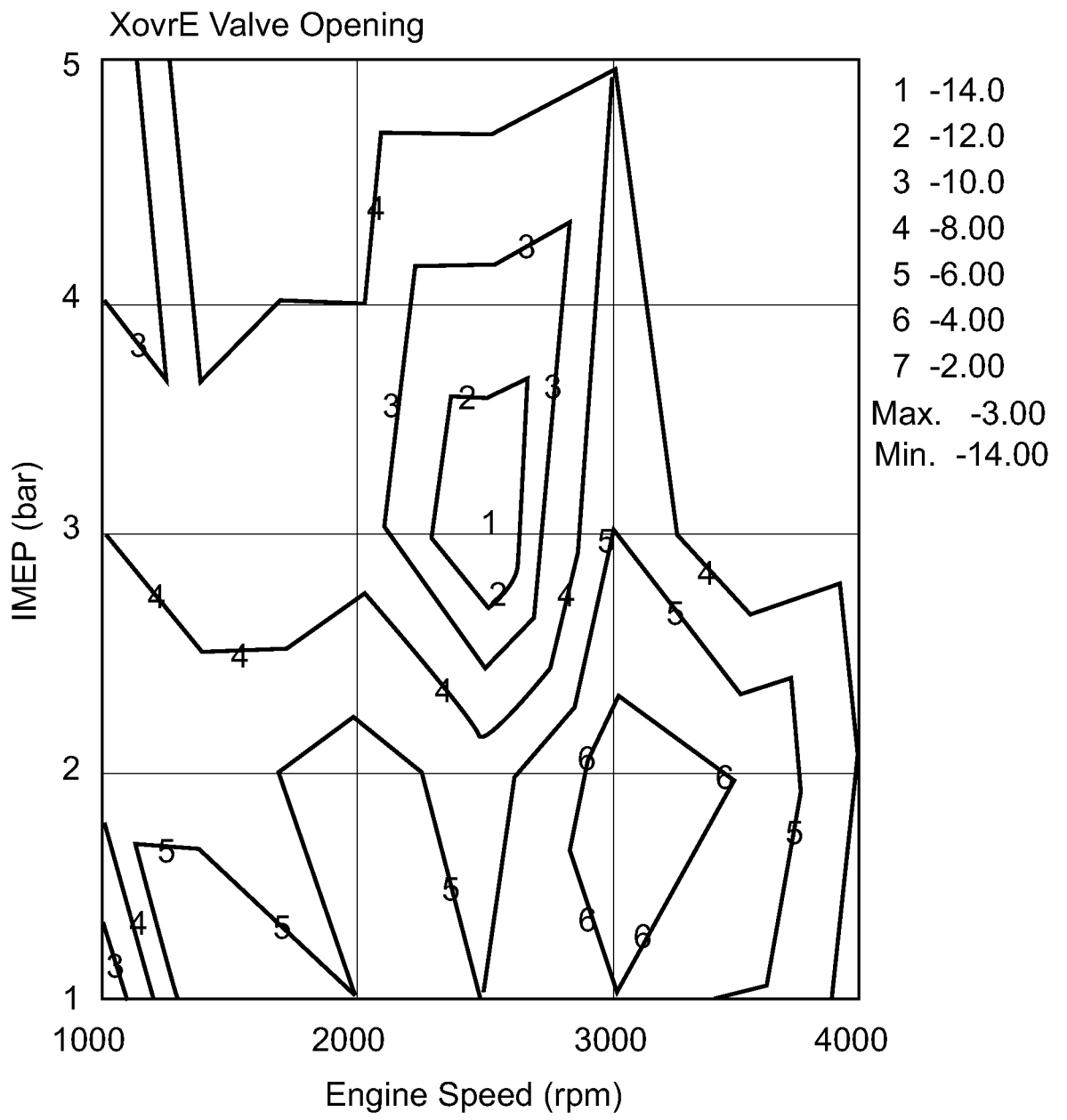

10/14

FIG. 10

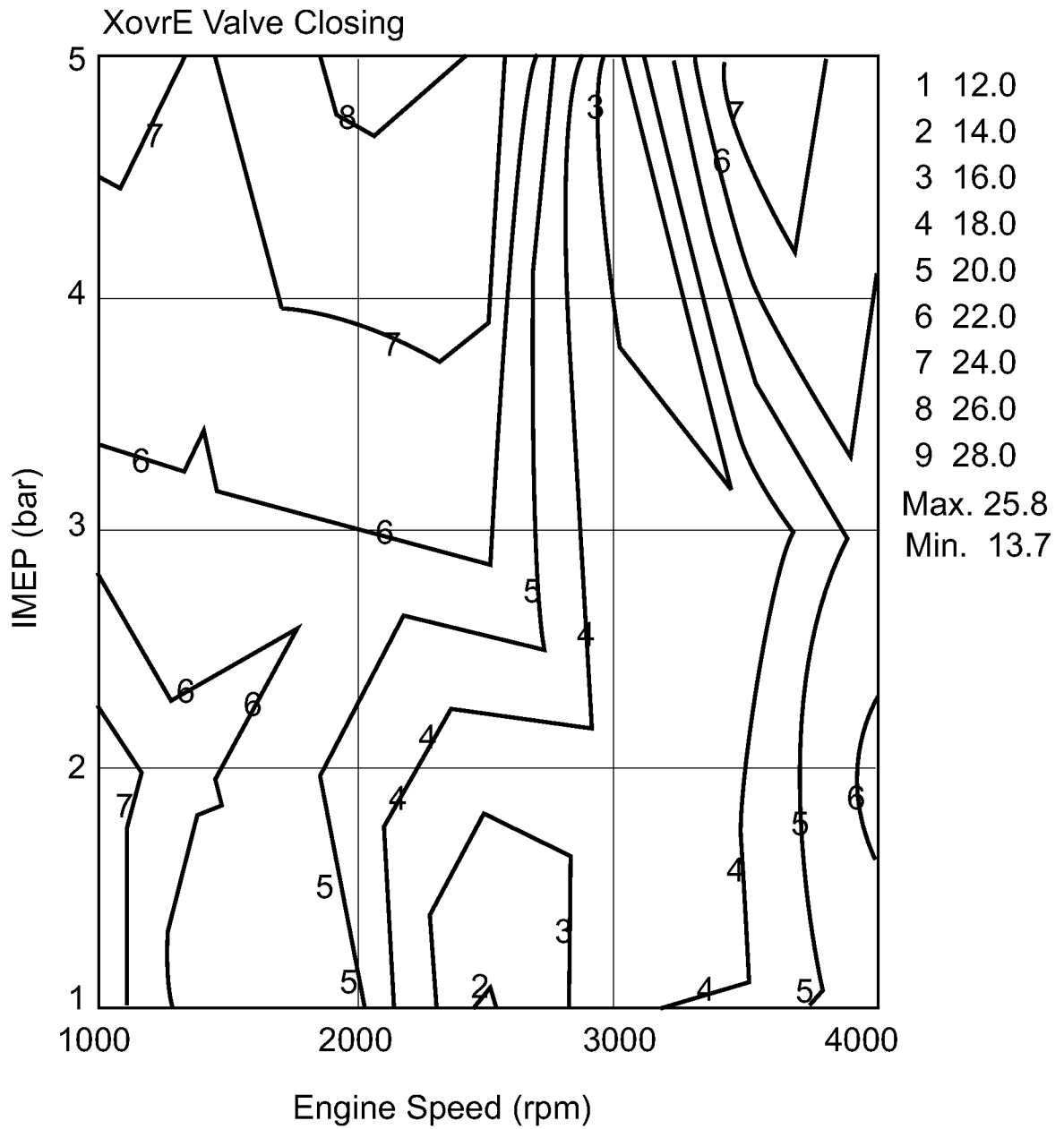

11/14

FIG. 11

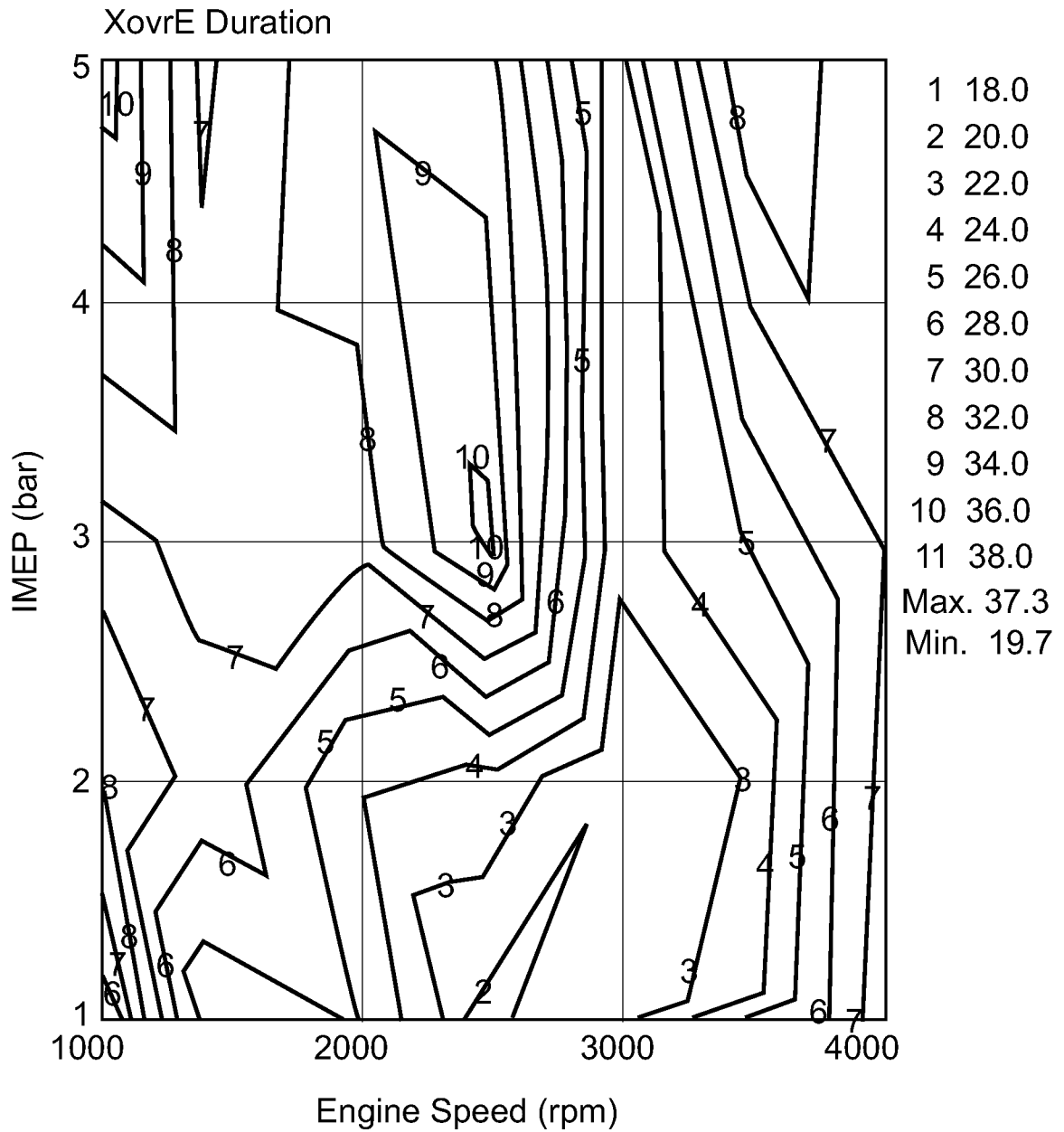

FIG. 12

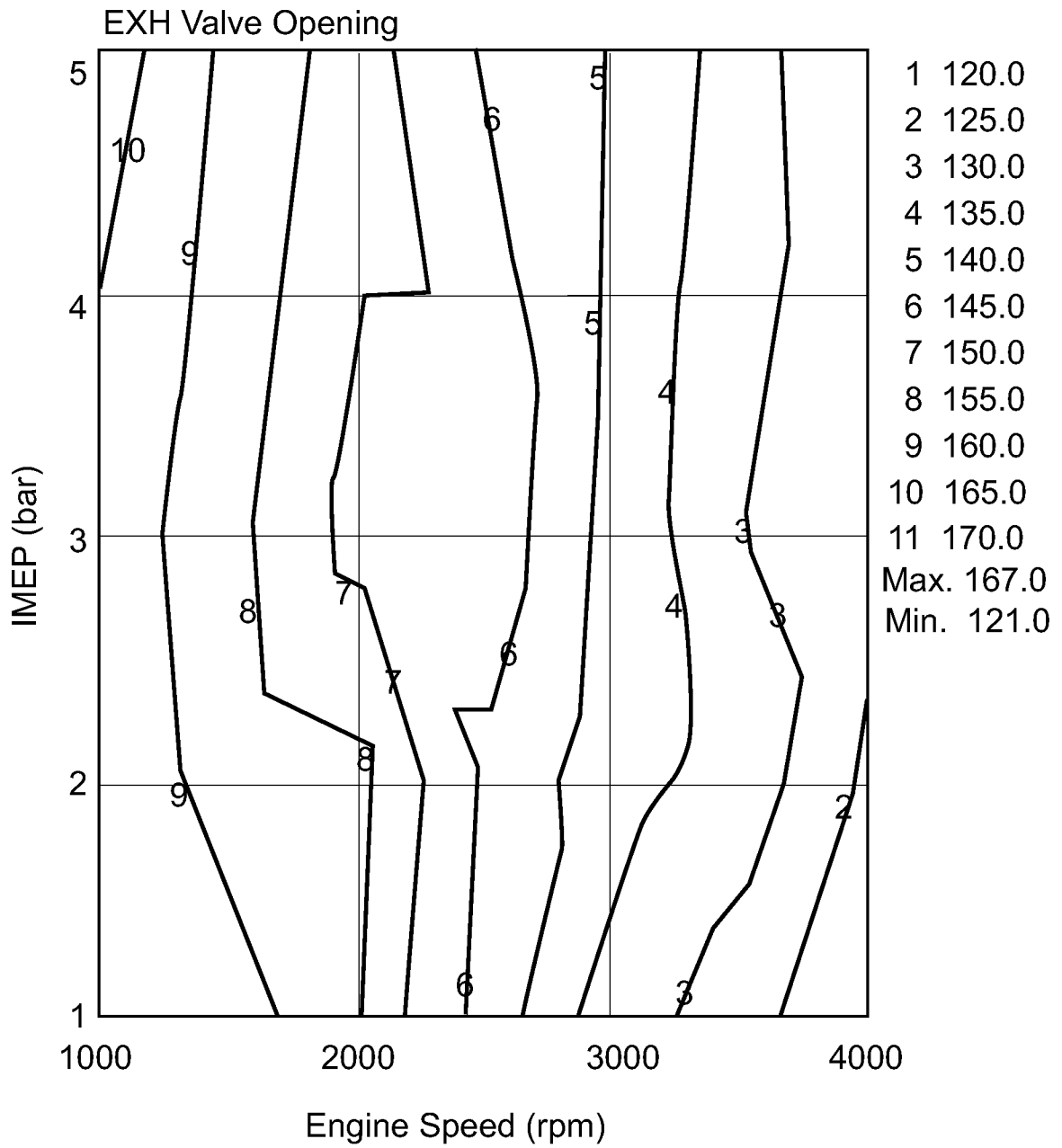

FIG. 13

EXH Valve Closing

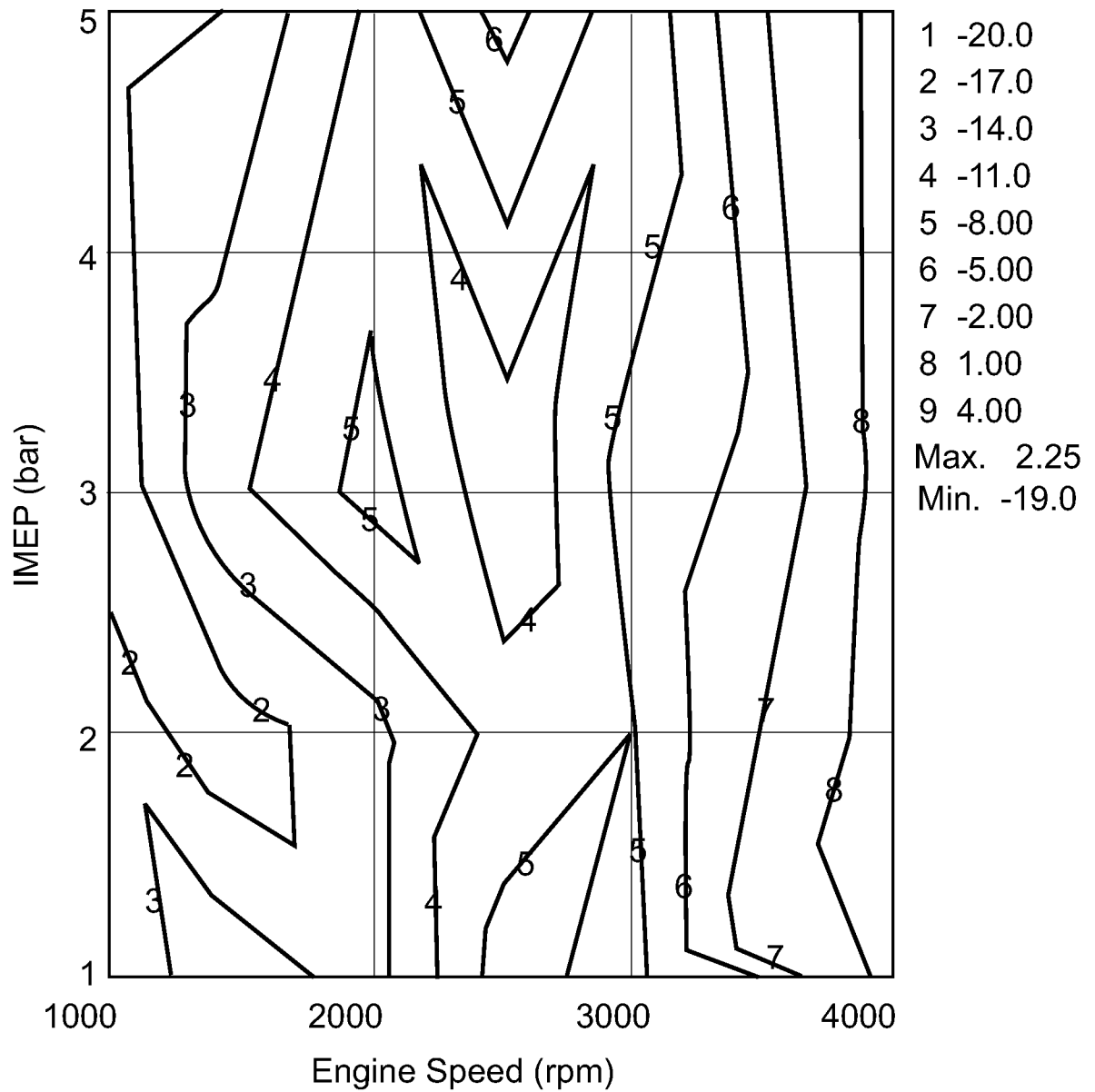
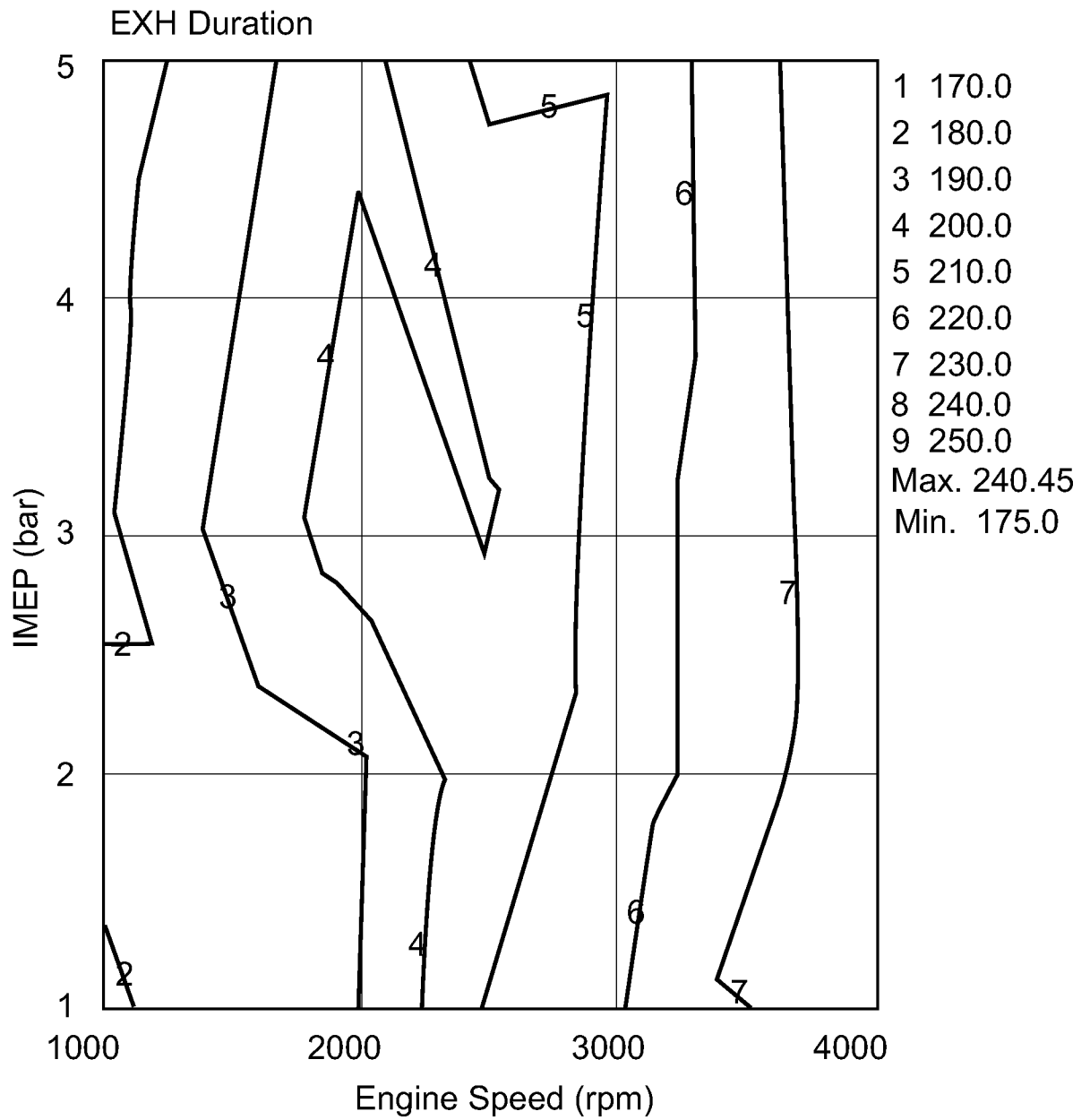

FIG. 14



INTERNATIONAL SEARCH REPORT

International application No.
PCT/US2011/028274

<p>A. CLASSIFICATION OF SUBJECT MATTER IPC(8) - F02B 33/22 (2011.01) USPC - 123/70R According to International Patent Classification (IPC) or to both national classification and IPC</p>																				
<p>B. FIELDS SEARCHED</p> <p>Minimum documentation searched (classification system followed by classification symbols) IPC(8) - F02B 33/22 (2011.01) USPC -60/620, 712; 91/181; 123/27R, 52.3, 52.5, 53.1, 53.5, 58.8, 68, 70R, 253, 258, 286, 292; 417/237</p> <p>Documentation searched other than minimum documentation to the extent that such documents are included in the fields searched</p> <p>Electronic data base consulted during the international search (name of data base and, where practicable, search terms used) PatBase, Google Patent</p>																				
<p>C. DOCUMENTS CONSIDERED TO BE RELEVANT</p> <table border="1"> <thead> <tr> <th>Category*</th> <th>Citation of document, with indication, where appropriate, of the relevant passages</th> <th>Relevant to claim No.</th> </tr> </thead> <tbody> <tr> <td>X - Y</td> <td>US 2009/0272368 A1 (BRANYON et al) 05 November 2009 (05.11.2009) entire document</td> <td>1-5, 7-11</td> </tr> <tr> <td>Y</td> <td>US 2007/0157894 A1 (SCUDERI et al) 12 July 2007 (12.07.2007) entire document</td> <td>6, 12</td> </tr> <tr> <td>A</td> <td>US 2006/0124085 A1 (LUTTGEHARM) 15 June 2006 (15.06.2006) entire document</td> <td>6, 12</td> </tr> <tr> <td>A</td> <td>US 4,696,158 A (DEFRANCISCO) 29 September 1987 (29.09.1987) entire document</td> <td>1-12</td> </tr> <tr> <td>A</td> <td>US 1,350,570 A (SARJENT) 24 August 1920 (24.08.1920) entire document</td> <td>1-12</td> </tr> </tbody> </table>			Category*	Citation of document, with indication, where appropriate, of the relevant passages	Relevant to claim No.	X - Y	US 2009/0272368 A1 (BRANYON et al) 05 November 2009 (05.11.2009) entire document	1-5, 7-11	Y	US 2007/0157894 A1 (SCUDERI et al) 12 July 2007 (12.07.2007) entire document	6, 12	A	US 2006/0124085 A1 (LUTTGEHARM) 15 June 2006 (15.06.2006) entire document	6, 12	A	US 4,696,158 A (DEFRANCISCO) 29 September 1987 (29.09.1987) entire document	1-12	A	US 1,350,570 A (SARJENT) 24 August 1920 (24.08.1920) entire document	1-12
Category*	Citation of document, with indication, where appropriate, of the relevant passages	Relevant to claim No.																		
X - Y	US 2009/0272368 A1 (BRANYON et al) 05 November 2009 (05.11.2009) entire document	1-5, 7-11																		
Y	US 2007/0157894 A1 (SCUDERI et al) 12 July 2007 (12.07.2007) entire document	6, 12																		
A	US 2006/0124085 A1 (LUTTGEHARM) 15 June 2006 (15.06.2006) entire document	6, 12																		
A	US 4,696,158 A (DEFRANCISCO) 29 September 1987 (29.09.1987) entire document	1-12																		
A	US 1,350,570 A (SARJENT) 24 August 1920 (24.08.1920) entire document	1-12																		
<p><input type="checkbox"/> Further documents are listed in the continuation of Box C. <input type="checkbox"/></p>																				
<p>* Special categories of cited documents:</p> <table border="0"> <tr> <td> <p>"A" document defining the general state of the art which is not considered to be of particular relevance</p> <p>"E" earlier application or patent but published on or after the international filing date</p> <p>"L" document which may throw doubts on priority claim(s) or which is cited to establish the publication date of another citation or other special reason (as specified)</p> <p>"O" document referring to an oral disclosure, use, exhibition or other means</p> <p>"P" document published prior to the international filing date but later than the priority date claimed</p> </td> <td> <p>"T" later document published after the international filing date or priority date and not in conflict with the application but cited to understand the principle or theory underlying the invention</p> <p>"X" document of particular relevance; the claimed invention cannot be considered novel or cannot be considered to involve an inventive step when the document is taken alone</p> <p>"Y" document of particular relevance; the claimed invention cannot be considered to involve an inventive step when the document is combined with one or more other such documents, such combination being obvious to a person skilled in the art</p> <p>"&" document member of the same patent family</p> </td> </tr> </table>			<p>"A" document defining the general state of the art which is not considered to be of particular relevance</p> <p>"E" earlier application or patent but published on or after the international filing date</p> <p>"L" document which may throw doubts on priority claim(s) or which is cited to establish the publication date of another citation or other special reason (as specified)</p> <p>"O" document referring to an oral disclosure, use, exhibition or other means</p> <p>"P" document published prior to the international filing date but later than the priority date claimed</p>	<p>"T" later document published after the international filing date or priority date and not in conflict with the application but cited to understand the principle or theory underlying the invention</p> <p>"X" document of particular relevance; the claimed invention cannot be considered novel or cannot be considered to involve an inventive step when the document is taken alone</p> <p>"Y" document of particular relevance; the claimed invention cannot be considered to involve an inventive step when the document is combined with one or more other such documents, such combination being obvious to a person skilled in the art</p> <p>"&" document member of the same patent family</p>																
<p>"A" document defining the general state of the art which is not considered to be of particular relevance</p> <p>"E" earlier application or patent but published on or after the international filing date</p> <p>"L" document which may throw doubts on priority claim(s) or which is cited to establish the publication date of another citation or other special reason (as specified)</p> <p>"O" document referring to an oral disclosure, use, exhibition or other means</p> <p>"P" document published prior to the international filing date but later than the priority date claimed</p>	<p>"T" later document published after the international filing date or priority date and not in conflict with the application but cited to understand the principle or theory underlying the invention</p> <p>"X" document of particular relevance; the claimed invention cannot be considered novel or cannot be considered to involve an inventive step when the document is taken alone</p> <p>"Y" document of particular relevance; the claimed invention cannot be considered to involve an inventive step when the document is combined with one or more other such documents, such combination being obvious to a person skilled in the art</p> <p>"&" document member of the same patent family</p>																			
<p>Date of the actual completion of the international search</p> <p>02 May 2011</p>		<p>Date of mailing of the international search report</p> <p>12 MAY 2011</p>																		
<p>Name and mailing address of the ISA/US</p> <p>Mail Stop PCT, Attn: ISA/US, Commissioner for Patents P.O. Box 1450, Alexandria, Virginia 22313-1450 Facsimile No. 571-273-3201</p>		<p>Authorized officer:</p> <p>Blaine R. Copenheaver</p> <p>PCT Helpdesk: 571-272-4300 PCT OSP: 571-272-7774</p>																		